

Introduction to Electron Tubes

Course No: E05-002

Credit: 5 PDH

A. Bhatia

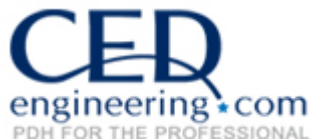

Continuing Education and Development, Inc.
22 Stonewall Court
Woodcliff Lake, NJ 07677

P: (877) 322-5800
info@cedengineering.com

CHAPTER 1

INTRODUCTION TO ELECTRON TUBES

LEARNING OBJECTIVES

Learning objectives are stated at the beginning of each chapter. These learning objectives serve as a preview of the information you are expected to learn in the chapter. The comprehensive check questions are based on the objectives. By successfully completing the OCC/ECC, you indicate that you have met the objectives and have learned the information. The learning objectives are listed below.

Upon completion of this chapter, you will be able to:

1. State the principle of thermionic emission and the Edison Effect and give the reasons for electron movement in vacuum tubes.
2. Identify the schematic representation for the various electron tubes and their elements.
3. Explain how the diode, triode, tetrode, and pentode electron tubes are constructed, the purpose of the various elements of the tube, and the theory of operation associated with each tube.
4. State the advantages, disadvantages, and limitations of the various types of electron tubes.
5. Describe amplification in the electron tube, the classes of amplification, and how amplification is obtained.
6. Explain biasing and the effect of bias in the electron tube circuit.
7. Describe the effects the physical structure of a tube has on electron tube operation and name the four most important tube constants that affect efficient tube operation.
8. Describe, through the use of a characteristic curve, the operating parameters of the electron tube.

INTRODUCTION TO ELECTRON TUBES

In previous study you have learned that current flows in the conductor of a completed circuit when a voltage is present. You learned that current and voltage always obey certain laws. In electronics, the laws still apply. You will use them continuously in working with electronic circuits.

One basic difference in electronic circuits that will at first seem to violate the basic laws is that electrons flow across a gap, a break in the circuit in which there appears to be no conductor. A large part of the field of electronics and the entire field of electron tubes are concerned with the flow and control of these electrons "across the gap." The following paragraphs will explain this interesting phenomenon.

THERMIONIC EMISSION

You will remember that metallic conductors contain many free electrons, which at any given instant are not bound to atoms. These free electrons are in continuous motion. The higher the temperature of the conductor, the more agitated are the free electrons, and the faster they move. A temperature can be

reached where some of the free electrons become so agitated that they actually escape from the conductor. They "boil" from the conductor's surface. The process is similar to steam leaving the surface of boiling water.

Heating a conductor to a temperature sufficiently high causing the conductor to give off electrons is called **THERMIONIC EMISSION**. The idea of electrons leaving the surface is shown in figure 1-1.

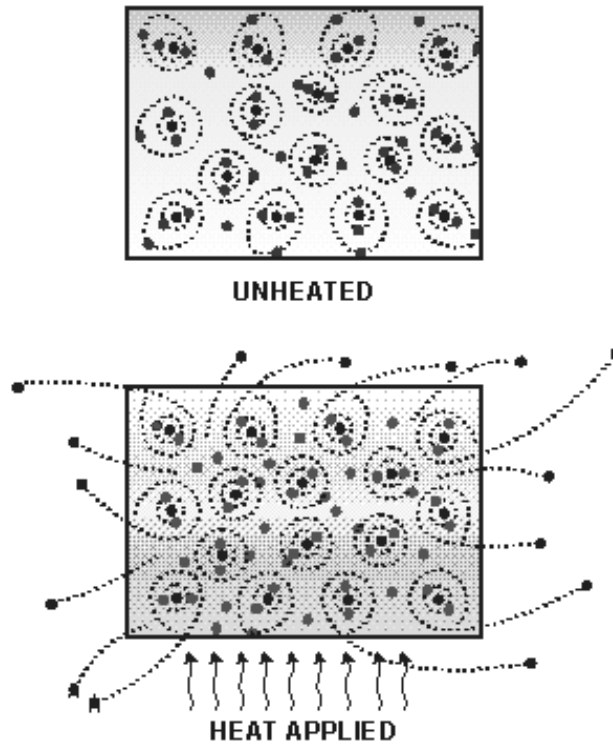

Figure 1-1.—Thermionic emission.

Thomas Edison discovered the principle of thermionic emission as he looked for ways to keep soot from clouding his incandescent light bulb. Edison placed a metal plate inside his bulb along with the normal filament. He left a gap, a space, between the filament and the plate. He then placed a battery in series between the plate and the filament, with the positive side toward the plate and the negative side toward the filament. This circuit is shown in figure 1-2.

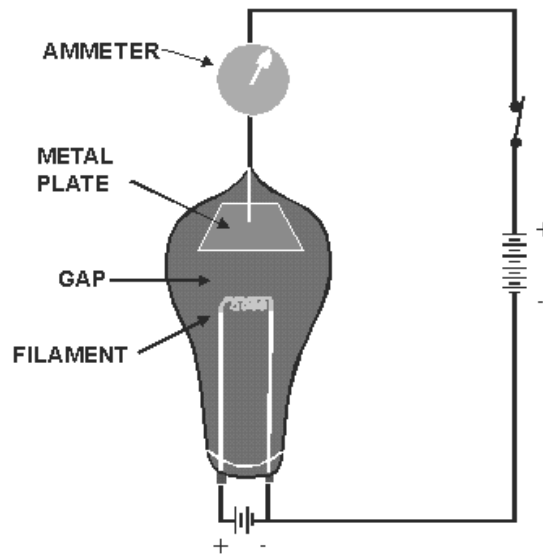

Figure 1-2.—Edison's experimental circuit.

When Edison connected the filament battery and allowed the filament to heat until it glowed, he discovered that the ammeter in the filament-plate circuit had deflected and remained deflected. He reasoned that an electrical current must be flowing in the circuit—**EVEN ACROSS THE GAP** between the filament and plate.

Edison could not explain exactly what was happening. At that time, he probably knew less about what makes up an electric circuit than you do now. Because it did not eliminate the soot problem, he did little with this discovery. However, he did patent the incandescent light bulb and made it available to the scientific community.

Let's analyze the circuit in figure 1-2. You probably already have a good idea of how the circuit works. The heated filament causes electrons to boil from its surface. The battery in the filament-plate circuit places a **POSITIVE** charge on the plate (because the plate is connected to the positive side of the battery). The electrons (negative charge) that boil from the filament are attracted to the positively charged plate. They continue through the ammeter, the battery, and back to the filament. You can see that electron flow across the space between filament and plate is actually an application of a basic law you already know—**UNLIKE CHARGES ATTRACT**.

Remember, Edison's bulb had a vacuum so the filament would glow without burning. Also, the space between the filament and plate was relatively small. The electrons emitted from the filament did not have far to go to reach the plate. Thus, the positive charge on the plate was able to attract the negative electrons.

The key to this explanation is that the electrons were floating free of the hot filament. It would have taken hundreds of volts, probably, to move electrons across the space if they had to be forcibly pulled from a cold filament. Such an action would destroy the filament and the flow would cease.

The application of thermionic emission that Edison made in causing electrons to flow across the space between the filament and the plate has become known as the **EDISON EFFECT**. It is fairly simple

and extremely important. Practically everything that follows will be related in some way to the Edison effect. Be sure you have a good understanding of it before you go on.

Q1. How can a sheet of copper be made to emit electrons thermionically?

Q2. Why do electrons cross the gap in a vacuum tube?

THE DIODE TUBE

The diode vacuum tube we are about to study is really Edison's old incandescent bulb with the plate in it. Diode means two elements or two electrodes, and refers to the two parts within the glass container that make up the tube. We have called them *filament* and *plate*. More formally, they are called **CATHODE** and **PLATE**, respectively. Sometimes the filament is called a **HEATER**, for obvious reasons—more on this later.

Within a few years after the discovery of the Edison effect, scientists had learned a great deal more than Edison knew at the time of his discovery. By the early 1900s, J.J. Thomson in England had discovered the electron. Marconi, in Italy and England, had demonstrated the wireless, which was to become the radio. The theoretical knowledge of the nature of electricity and things electrical was increasing at a rapid rate.

J.A. Fleming, an English scientist, was trying to improve on Marconi's relatively crude wireless receiver when his mind went back to Edison's earlier work. His subsequent experiments resulted in what became known as the **FLEMING VALVE** (the diode), the first major step on the way to electronics.

OPERATION OF THE DIODE TUBE

Before learning about Fleming's valve, the forerunner of the modern diode, let's look at Edison's original circuit. This time, however, we'll draw it as a schematic diagram, using the symbol for a diode instead of a cartoon-like picture. The schematic is shown in figure 1-3.

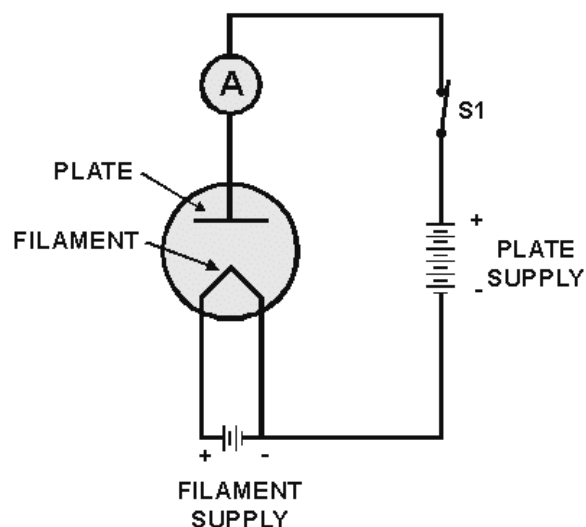

Figure 1-3.—Schematic of Edison's experimental circuit.

Note that this is really two series circuits. The filament battery and the filament itself form a series circuit. This circuit is known as the *filament circuit*.

The path of the second series circuit is from one side of the filament, across the space to the plate, through the ammeter and battery, then back to the filament. This circuit is known as the plate circuit.

You will note that a part of the filament circuit is also common to the plate circuit. This part enables the electrons boiled from the filament to return to the filament. No electron could flow anywhere if this return path were not completed. The electron flow measured by the ammeter is known as plate current.

The voltage applied between the filament and plate is known as plate voltage. You will become familiar with these terms and with others that are commonly used with diodes and diode circuits as we progress.

Diode Operation with a Positive Plate

Fleming started with a two-element tube (diode) similar to Edison's and at first duplicated Edison's experiment. The results are worth repeating here. Look at figure 1-3 again.

With the plate **POSITIVE** relative to the filament, the filament hot, and the circuit completed as shown, the ammeter detected a current flowing in the plate circuit. Because current is the same in all parts of a series circuit, we know that the same current must flow across the space between filament and plate. We know now that the electrons boiled from the heated filament are **NEGATIVE** and are attracted to the **POSITIVE** plate because **UNLIKE CHARGES ATTRACT**.

Diode Operation with a Negative Plate

Fleming's next step was to use a similar circuit but to reverse the plate battery. The circuit is shown in figure 1-4.

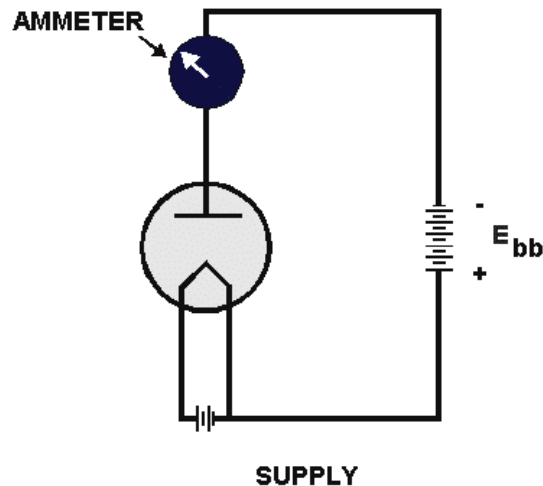

Figure 1-4.—Diode with a negative plate.

With the plate **NEGATIVE** relative to the filament, the filament hot, and the circuit completed as shown, the ammeter indicated that **ZERO** current was flowing in the plate circuit.

Fleming found that the **NEGATIVE** charge on the plate, relative to the filament, **CUT OFF** the flow of plate current as effectively as if a **VALVE** were used to stop the flow of water in a pipe.

You have all of the facts available that Fleming had. Can you give an explanation of why the diode cuts off current when the plate is negative?

Let's put the facts together. The filament is hot and electrons boil from its surface. Because the filament is the only heated element in the diode, it is the **ONLY** source of electrons within the space between filament and plate. However, because the plate is **NEGATIVE** and the electrons are **NEGATIVE**, the electrons are repelled back to the filament. Remember that **LIKE CHARGES REPEL**. If electrons cannot flow across the space, then no electrons can flow anywhere in the plate circuit. The ammeter therefore indicates **ZERO**.

It might seem to you that electrons flow from the negative plate to the positive filament under these conditions. This is **NOT** the case. Remember that it takes a heated element to emit electrons and that the filament is the only heated element in the diode. The plate is cold. Therefore, electrons cannot leave the plate, and plate-to-filament current cannot exist.

The following is a summary of diode operation as we have covered it to this point:

Assume that all parts of the circuit are operable and connected.

- PLATE CURRENT FLOWS WHEN THE PLATE IS POSITIVE.
- PLATE CURRENT IS CUT OFF WHEN THE PLATE IS NEGATIVE.
- PLATE CURRENT FLOWS ONLY IN ONE DIRECTION-FROM THE FILAMENT TO THE PLATE.

Measuring Diode Voltages

As you know, it is impossible to have a voltage at one point, because voltage is defined as a **DIFFERENCE** of **POTENTIAL** between two points. In our explanation above we referred to plate voltage. To be exactly right, we should refer to plate voltage as the **VOLTAGE BETWEEN PLATE** and **FILAMENT**. Plate voltages, and others that you will learn about soon, are often referred to as if they appear at one point. This should not confuse you if you remember your definition of voltage and realize that voltage is always measured between two points. M1 and M2 in figure 1-5 measure plate voltage and filament voltage, respectively.

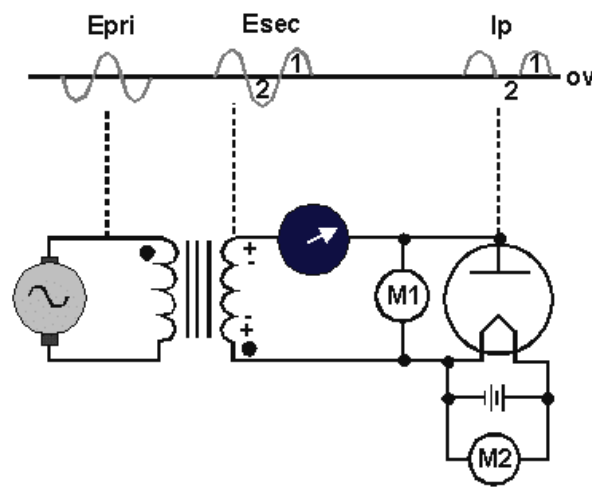

Figure 1-5.—Alternating voltage on the plate.

The reference point in diode and other tube circuits is usually a common point between the individual circuits within the tube. The reference point (common) in figure 1-5 is the conductor between the bottom of the transformer secondary and the negative side of the filament battery. Note that one side of each voltmeter is connected to this point.

Q3. Name the two series circuits that exist in a diode circuit.

Q4. Before a diode will conduct, the cathode must be what polarity relative to the plate?

Diode Operation with an Alternating Voltage on the Plate

After experimenting with a positive plate and a negative plate, Fleming replaced the direct voltage of the battery with an alternating voltage. In our explanation, we'll use a transformer as the source of alternating voltage. The circuit is shown in figure 1-5.

Note that the only real difference in this circuit from the previous ones is the transformer. The transformer secondary is connected in series with the plate circuit—where the plate battery was previously.

Remember from your study of transformers that the secondary (output) of a transformer always produces an alternating voltage. The secondary voltage is a sine wave as shown in the figure.

You'll remember that the sine wave is a visual picture, a graph of the change in alternating voltage as it builds from zero to a maximum value (positive) and then drops to zero again as it decreases to its minimum value (negative) in the cycle.

Assume that the polarity across the secondary during the first half-cycle of the input ac voltage is as shown in the figure. During this entire first half-cycle period, the plate's polarity will be **POSITIVE**. Under this condition, plate current flows, as shown by the ammeter.

The plate current will rise and fall because the voltage on the plate is rising and falling. Remember that current in a given circuit is directly proportional to voltage.

During the second half-cycle period, plate's polarity will be **NEGATIVE**. Under this condition, for this entire period, the diode will not conduct. If our ammeter could respond rapidly, it would drop to zero. The plate-current waveform (I_p) in figure 1-5 shows zero current during this period.

Here is a summary of effects of applying alternating voltage to the plate of the diode:

1. Diode plate current flows during the positive half-cycle. It changes value as the plate voltage rises and falls.
2. The diode cuts off plate current during the entire period of the negative half-cycle.
3. Diode plate current flows in **PULSES** because the diode cuts off half the time.
4. Diode plate current can flow in only one direction. It is always a direct current. (In this case **PULSATING DC**—one that flows in pulses.)
5. In effect, the diode has caused an alternating voltage to produce a direct current.

The ability to obtain direct current from an ac source is very important and one function of a diode that you will see again and again wherever you work in electronics.

The circuits that we have discussed up to this point were chosen to show the general concepts discovered by Edison and Fleming. They are not practical because they do no useful work. For now, only the concepts are important. Practical circuitry will be presented later in this chapter as you learn specific points about the construction, limitations, and other characteristics of modern diode tubes.

Q5. An ac voltage is applied across a diode. The tube will conduct when what alternation of ac is applied to the plate?

Q6. What would be the output of the circuit described in question 5?

DIODE CONSTRUCTION

Diode tubes in present use are descendants of Fleming's valve. There is a family resemblance, but many changes have been made from the original. Diodes are both smaller and larger, less powerful and more powerful, and above all, more efficient and more reliable. The search for greater efficiency and reliability has resulted in many physical changes, a few of which will be covered in the next paragraphs.

Most of what is said here about construction and materials will be true of all electron tubes, not just diodes.

Filaments

Modern filaments in **ALL** tubes last longer, emit greater amounts of electrons for a given size, and many operate at a lower temperature than in the early days. Most improvements have resulted from the use of new materials and from better quality control during manufacture.

Three materials that are commonly used as filaments are tungsten, thoriated tungsten, and oxide-coated metals.

Tungsten has great durability but requires large amounts of power for efficient thermionic emission. Thoriated-tungsten filaments are made of tungsten with a very thin coat of thorium, which makes a much better emitter of electrons than just tungsten. Oxide-coated filaments are made of metal, such as nickel, coated with a mixture of barium and strontium oxides. The oxide coat, in turn, is coated with a one-molecule-thick layer of metal barium and strontium. Oxide coating produces great emission efficiency and long life at relatively low heat.

A major advance in electronics was the elimination of batteries as power sources for tubes. Except in electronic devices designed to be operated away from the ac power source, alternating current is used to heat filaments.

Voltage may be supplied by a separate filament transformer or it may be taken from a filament winding that is part of a power transformer. The actual voltage may vary from 1 volt up and depends on the design of the tube. Common filament voltages are 5.0, 6.3, and 12.6 volts ac. Filaments may be connected in series with other tube filaments or may be in parallel with each other. This is determined by the equipment designer.

Cathodes

As was mentioned previously, a more formal name for the electron-emitting element in a tube is the **CATHODE**.

Cathodes in all tubes, not just diodes, are of two general types, either directly heated or indirectly heated. Each has its advantages and disadvantages.

DIRECTLY HEATED.—The filament that has been discussed so far is the directly heated cathode. Directly heated cathodes are fairly efficient and are capable of emitting large amounts of electrons. Figure 1-6 shows this type and its schematic symbol.

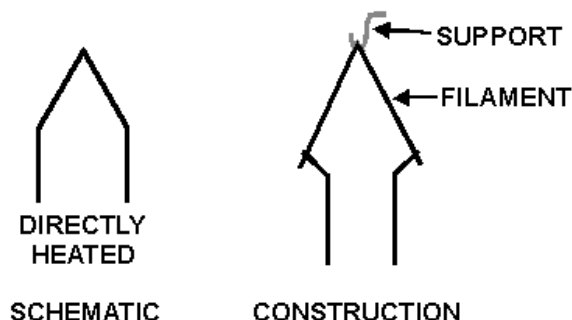

Figure 1-6.—Cathode schematic representation.

An added advantage of this type of filament is the rapidity with which it reaches electron-emitting temperature. Because this is almost instantaneous, many pieces of electronic equipment that must be turned on at infrequent intervals and be instantly usable have directly heated cathode tubes.

There are disadvantages. Because of its construction, parts of the filament are closer to the plate than other parts. This results in unequal emission and a loss of efficiency. Another disadvantage occurs when dc is used to heat a filament. The filament represents a resistance. When current flows through this resistance, a voltage drop occurs. The result is that one side of the resistance, or filament, is more negative than the other side. The negative side of the filament will emit more electrons than the positive side; which, again, is less efficient than if the filament has equal emission across its entire surface.

When ac is the source of filament power, it causes a small increase and decrease of temperature as it rises and falls. This causes a small increase and decrease of emitted electrons. This effect is not too important in many diode circuits, but it is undesirable in other tube circuits.

INDIRECTLY HEATED.—Figure 1-7 shows this type of cathode and its schematic symbol. Indirectly heated cathodes are always composed of oxide-coated material. The cathode is a cylinder, a kind of sleeve, that encloses the twisted wire filament. The only function of the filament is to heat the cathode. The filament is often called a heater when used in this manner.

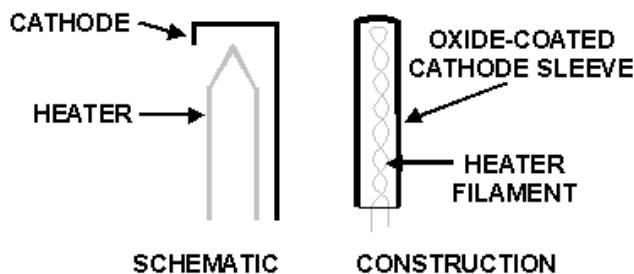

Figure 1-7.—Indirectly heated cathode schematic.

Some schematics do not show heaters and heater connections. Heaters, of course, are still present in the tubes, but their appearance in a schematic adds little to understanding the circuit. The heater is not considered to be an active element. For example, a tube with an indirectly heated cathode and a plate is still called a diode, even though it might seem that there are three elements in the tube.

Because indirectly heated cathodes are relatively large, they take longer to heat to electron-emitting temperature. Once up to temperature, however, they do not respond to the small variations in heater temperature caused by ac fluctuations. Because of the inherent advantages, most tubes in use today have indirectly heated cathodes.

Q7. Besides tungsten, what other materials are used for cathodes in vacuum tubes?

Q8. What is the advantage of directly heated cathodes?

Plates

Edison's plate was just that—a plate, a flat piece of metal. Plates are no longer flat but are designed in many different shapes. Figure 1-8 shows two diodes, one with a directly heated cathode, the other with an indirectly heated cathode. Each plate is cut away to show the internal position of elements and the plate shapes.

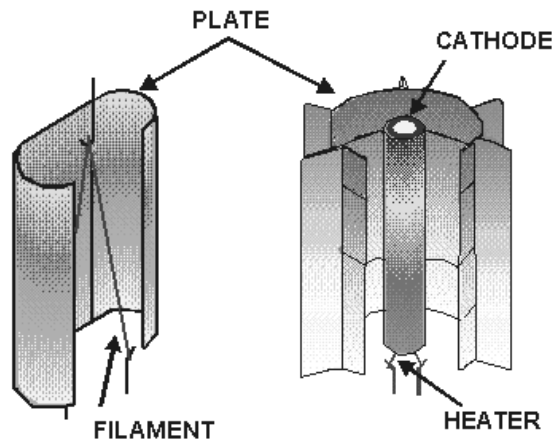

Figure 1-8.—Cutaway view of plate construction.

Plates must be able to hold up under the stress of heat created by the flow of plate currents and the closeness of hot cathodes. They need to be strong enough to withstand mechanical shocks produced by vibration and handling.

Some typical materials used for electron tube plates are tungsten, molybdenum, graphite, nickel, tantalum, and copper.

Tube Bases

The base shown in figure 1-9 has two functions. First, it serves as the mounting for tube elements. Second, it serves as the terminal points for the electrical connections to the tube elements. This is accomplished by molding or otherwise bringing pins (or prongs) through the base. The internal ends of these pins are connected to tube elements. The pins themselves are male connections.

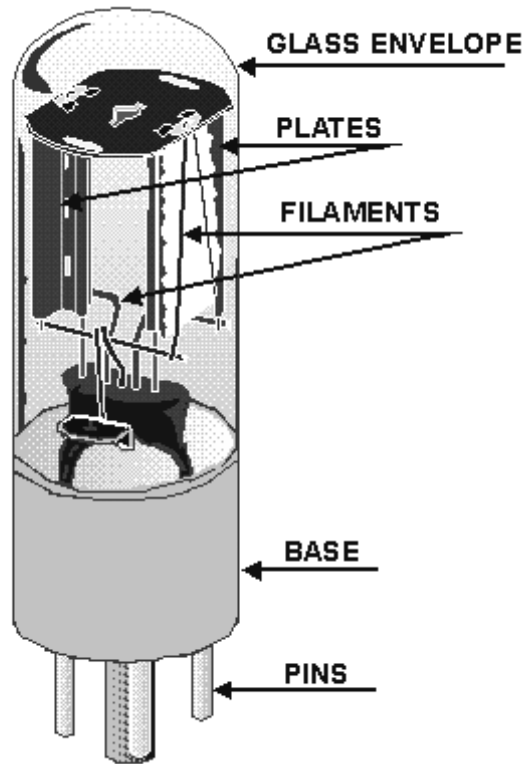

Figure 1-9.—Diode construction.

The base must be mechanically strong and made of an insulating material to prevent the tube elements from shorting.

Because they require relatively frequent replacement, most tubes are designed to plug into sockets permanently mounted in the equipment. Tube pins and sockets are so designed that tubes cannot be plugged in incorrectly.

Tube sockets must make secure mechanical and electrical contact with tube pins, must insulate pins from each other, and must provide terminals to which circuit components and conductors are connected.

Each element of a tube is connected to a pin in its base. To trace a circuit easily and efficiently, you must match elements with their pin numbers. This information is available in tube manuals and equipment schematics. Figure 1-10 shows these numbers on one example of a diode symbol. You will also note the designation V1 beside the tube. Electron tubes are often identified in schematic diagrams by the letter V and a number.

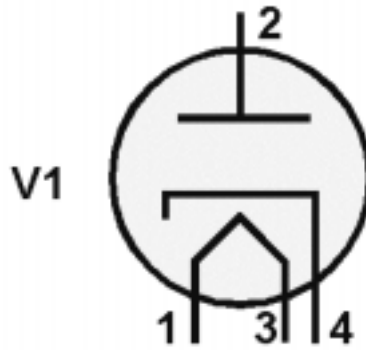

Figure 1-10.—Identification of tube elements.

Now, to use the information in the symbol, you need to know the system used to number tube pins and socket connections.

Figure 1-11 shows five common pin configurations as viewed from the bottom of each tube or socket. This is important. In every case, pins and pin connections on sockets are numbered in a clockwise direction—**WHEN VIEWED FROM THE BOTTOM**.

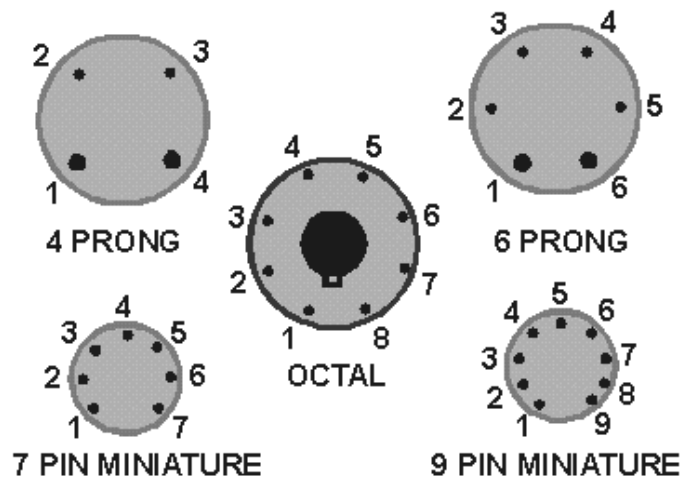

Figure 1-11.—Pin Identification; all tubes are viewed from the bottom.

In each of the five pictures in figure 1-11, there is an easily identified point from which to start numbering. In the 4-prong and 6-prong tubes, the point is between the two larger prongs. In the octal tube, the point is directly down from the keyway in the center of the tube. In the 7-pin and 9-pin miniatures, the point is identified by the larger distance between pins.

Q9. Name two functions of the base of a vacuum tube.

The Envelope

The envelope of a tube may be made of ceramic, metal, or glass. Its major purpose is to keep the vacuum in and the atmosphere out. The main reason for this is that the heated filament would burn up in the atmosphere. There are other reasons for providing a vacuum, but the important thing is to realize that a tube with a leaky envelope will not function properly.

The silver spot you will sometimes see on the inside surface of the glass envelope of a vacuum tube is normal. It was caused by the "flashing" of a chemical during the manufacture of the tube. Burning the chemical, called the **GETTER**, helps to produce a better vacuum and eliminates any remaining gases.

ELECTRICAL PARAMETERS OF DIODES

Thousands of different tubes exist. While many of them are similar and even interchangeable, many have unique characteristics. The differences in materials, dimensions, and other physical characteristics, such as we have just covered, result in differing electrical characteristics.

The electrical parameters of a diode, and any tube, are specific. In the process of discussing these parameters, we will state exact values. Voltages will be increased and decreased and the effects measured. Limiting factors and quantities will be explored and defined. The discussion will be based on simplified and experimental circuits.

It is important for you to realize that practically all of the parameters, limitations, definitions, abbreviations, and so on that we will cover in these next paragraphs will apply directly to the more complex tubes and circuits you will study later. Diode parameters are the foundation for all that follows.

Symbols

You have learned to use letters and letter combinations to abbreviate or symbolize electrical quantities. (The letters E, I, and R are examples.) We will continue this practice in referring to tube quantities. You should be aware that other publications may use different abbreviations. Many attempts have been made to standardize such abbreviations, inside the Navy and out. None have succeeded completely.

Table 1-1 lists electron-tube symbols used in the remainder of this chapter. The right-hand column shows equivalent symbols that you may find in **OTHER** texts and courses.

Table 1-1.—Symbols for Tube Parameters

SYMBOLS THIS TEXT	MEANING	OTHER TEXTS
E_p	PLATE VOLTAGE, D.C. VALUE	
E_{bb}	PLATE SUPPLY VOLTAGE, D.C.	B+
E_c	GRID BIAS VOLTAGE, D.C. VALUE	E_g
E_{cc}	GRID BIAS SUPPLY VOLTAGE, D.C.	C-
e_b	INSTANTANEOUS PLATE VOLTAGE	
e_c	INSTANTANEOUS GRID VOLTAGE	
e_g	A.C. COMPONENT OF GRID VOLTAGE	
e_p	A.C. COMPONENT OF PLATE VOLTAGE (ANODE)	
I_p	D.C. PLATE CURRENT	
R_p	D.C. PLATE RESISTANCE	
R_g	GRID RESISTANCE	
R_k	CATHODE RESISTANCE	
R_L	LOAD RESISTANCE	

Plate Voltage-Plate Current Characteristic

You know that a positive voltage on the diode plate allows current to flow in the plate circuit. Each diode, depending on the physical and electrical characteristics designed into the diode, is able to pass an exact amount of current for each specific plate voltage (more voltage, more current—at least to a point).

The plate voltage-plate current characteristic for a given diode is a measure of exactly how much plate voltage controls how much plate current. This is often called the $E_p - I_p$ characteristic.

The $E_p - I_p$ characteristic for a given diode, is determined by design engineers using mathematical analysis and laboratory experiment. You, as a technician, will never need to do this. However, you will use the results obtained by the engineers. You will also use your knowledge of the diode as you analyze equipment malfunction.

Assume that we have the circuit in figure 1-12. (The filament has the proper voltage-even though it isn't shown on the diagram.) Our purpose is to determine just how a changing voltage on the plate changes (or controls) the plate current. The method is as follows:

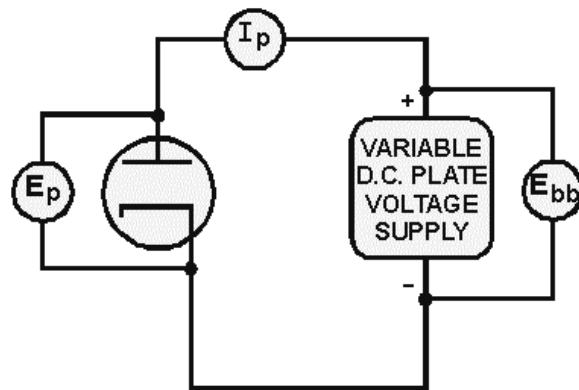

Figure 1-12.—Determining diode plate characteristic.

1. Starting with zero volts from our variable dc voltage source, increase the plate voltage (E_p) in steps of 50 volts until you reach 400 volts.
2. At a each 50-volt step, measure the milliamperes of plate current (I_p) that flow through the meter. Record the I_p meter readings, step by step, so that you may analyze the results.

Assume that table 1-2 shows our results. While we could use the table, a more normal procedure is to plot a graph of the values. Such a graph is called an $E_p - I_p$ CURVE and is shown in figure 1-13. Each tube has its own $E_p - I_p$ curve, which is available in commercial tube manuals and in many equipment technical manuals. Each curve will be different in some respects from every other curve. The shapes, however, will be similar.

Table 1-2.— $E_p - I_p$ Values Obtained by Experiment

E_p	0	50	100	150	200	250	300	350	400
I_p	0	.002	.005	.010	.020	.030	.040	.042	.045

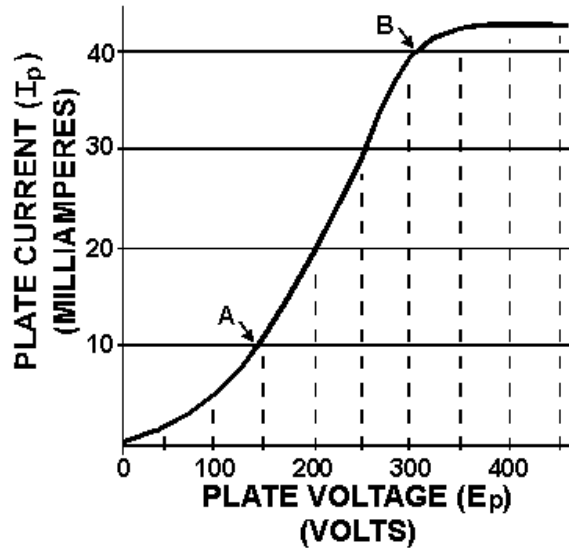

Figure 1-13.— $E_p - I_p$ characteristic curve.

The $E_p - I_p$ curve in figure 1-13, although just an example, is typical of real plate characteristic curves. You may learn certain characteristics that apply to both diodes and other tubes by studying it.

First, look at the part of the curve to the left of point A. Because it is not a straight line, it is referred to as **NONLINEAR**. Note that a change of 150 volts (0-150) caused a change of 10 mA of plate current (0-10). In comparison with the straight-line part of the curve, between points A and B, this is a relatively small change in current. The smaller the change in current, the flatter the curve.

In explaining this **NONLINEAR** portion of the curve, let's go back just a bit to electron emission. The electrons emitted by a cathode form a cloud around the cathode. This cloud is called the **SPACE CHARGE**. The closer the space charge is to the cathode, the more densely packed it is with electrons. In our example, the lower plate voltages (0-150 volts) over this part of the curve exert a pull on only the outer fringe of the space charge where there are few electrons. This results in relatively few electrons flowing to the plate.

Now look at the center portion of the curve between A and B. This is known as the **LINEAR** portion because it is nearly a **STRAIGHT LINE**. Over this portion, a change of 50 volts E_p causes a change of 10 mA I_p .

The reason for the increased change in plate current for a given change of plate voltage also has to do with the space charge. With a higher plate voltage (over 150 volts), the attraction from the plate begins to influence the **DENSER** part of the space charge that has greater numbers of electrons. Therefore, a higher current flows for a given voltage than in the nonlinear part. The curve becomes steeper. In our example, this linearity continues to about 300 volts, point B.

Lastly, let's look at the top portion of the curve. The plate current plotted here is produced by the higher plate voltages. However, the amount of current change for a given voltage change is greatly reduced. The reason for this again involves the space charge. At about 300 volts, almost all of the electrons in the space charge are flowing to the plate. A higher voltage cannot attract more electrons because the cathode cannot produce any more. The point where all (or almost all) available electrons are being drawn to the plate is called **PLATE SATURATION** or just **SATURATION**. This is one of the limiting factors of every tube.

You can see from the analysis that the most consistent control of plate current takes place over the linear portion of the $E_p - I_p$ curve. In most applications, electron tubes are operated in this linear portion of the characteristic curve.

Plate Resistance (R_p)

One tube parameter that can be calculated from values on the $E_p - I_p$ curve is known as plate resistance, abbreviated as R_p . In a properly designed electron tube, there is no physical resistor between cathode and plate; that is, the electrons do not pass through a resistor in arriving at the plate. You may have wondered, however, why the variable dc voltage source of figure 1-12 didn't blow a fuse. Doesn't the plate circuit appear to be a short circuit—a circuit without a load to limit the current?

The fact is, there is a very real, effective **RESISTANCE** between cathode and plate. It is not lumped in a resistor, but the circuit may be analyzed as if it is. The plate resistance of a given tube, R_p , can be calculated by applying Ohm's law to the values of E_p and I_p . Figure 1-14 is a typical diode $E_p - I_p$ curve. The plate resistance has been figured for R_p under three different conditions, as follows:

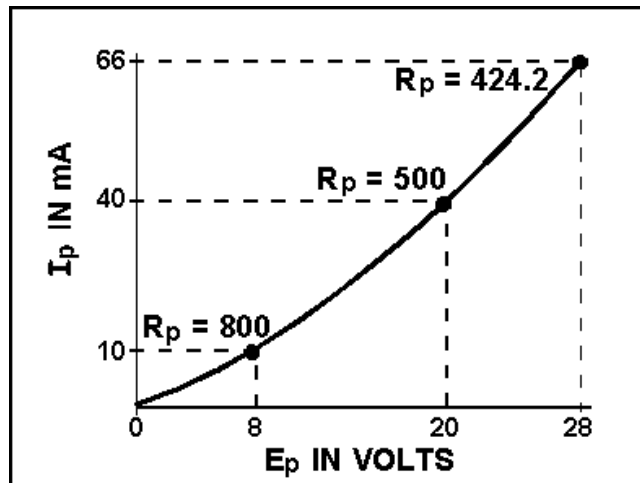

Figure 1-14.—The $E_p - I_p$ characteristic curve for a diode.

Remember that 1 mA = .001 ampere; therefore 40 mA = .040 ampere.

Solution:

$$R_p = \frac{E_p}{I_p}$$

$$R_p = \frac{20\text{volts}}{.040\text{ amperes}}$$

$$R_p = 500\text{ ohms}$$

The other two indicated values of R_p were figured in the same way.

You should note that there is very little difference in plate resistance when the E_p and I_p values are taken from the linear portions of curves. Check this out with values taken from the linear portion of figure 1-13.

R_p (with a capital R) is the effective resistance offered to direct current.

PLATE RESISTANCE IN GAS DIODES.—Gas diodes are a type of tube that we have not yet discussed. They are mentioned here only because of their plate-resistance characteristic.

Instead of a high-vacuum environment, some tubes have small amounts of gas introduced in the envelope vacuum during manufacture. Argon, neon, helium, or mercury vapor are commonly used.

When a certain minimum voltage is placed on the plate, the gas molecules in the envelope ionize. This happens by a process that will be explained when gas diodes are studied. The positive ions tend to cancel some of the effects of the space charge that influence plate resistance in a vacuum tube. This canceling reduces internal plate resistance to a relatively low, constant value. In applications that require a large plate current, the low plate resistance of a gas-filled diode has an efficiency that cannot be approached by a high-vacuum diode.

This and other characteristics of gas tubes will be covered later.

Q10. Vacuum tubes are designed to operate in what portion of the $E_p - I_p$ curve?

Q11. What value can be calculated from the values found on an $E_p - I_p$ curve?

Plate Dissipation

When electrons are attracted from the space charge to the plate, they are accelerated by the attraction. Their gain in speed gives them energy that causes them to strike the plate with a considerable force. As the electrons strike the plate, this energy is converted to heat. The plate must be able to withstand the associated increase in temperature. The maximum amount of power (watts) that a given plate can safely dissipate (as heat) is called the **PLATE DISSIPATION** rating.

To find the amount of plate dissipation for a given tube under a particular set of plate conditions, use the following equation:

$$\text{Plate dissipation} = E_p \times I_p$$

For our current problem,

$$\text{Plate dissipation} = 20 \text{ volts} \times .040 \text{ amperes}$$

$$\text{Plate dissipation} = .8 \text{ watt}$$

This is a relatively small wattage. It's probable that the plate of our example diode is not overheating. A tube manual could tell us for sure.

Plate dissipation is a circuit loss that must be made good by the power source in a circuit. In our example, this is the plate voltage supply.

Peak Current Rating

The maximum instantaneous current that a tube can pass in the normal direction (cathode to plate) without damage is called the **PEAK CURRENT RATING**. Peak current rating is determined by the amount of electrons available from the cathode and the length of time plate current flows.

Peak Voltage Rating

This is the maximum instantaneous voltage that can be applied to a tube in the normal direction without a breakdown.

Peak Inverse Voltage Rating

This is the maximum voltage that can be applied to a tube in the reverse direction (plate negative with respect to the cathode)-exceeding this will cause arc-over from the plate to the cathode and will damage the tube. **PIV**, as this is sometimes abbreviated, becomes very important in the rectifier circuit to be discussed as a later major subject.

Transit Time

Things that happen in electricity and electronics are often explained as if they happen instantaneously. As fast as electricity acts, however, the truth is that cause and effect are separated by a certain amount of time.

Each tube has a factor called **TRANSIT TIME**, which is the time required for an individual electron to move from the cathode to the plate. In certain applications involving high-frequency voltages, transit time places a limitation on tubes. We will explain this limitation when we discuss the circuits it affects.

Summary of Diode Parameters and Limitations

You should now have a basic understanding of diodes, many of their characteristics, and some of their limitations. One of the more important concepts that you should now understand is that most of these characteristics influence each other. For example, practically all plate characteristics are interrelated. Change one and the others change. Another example is heater voltage. Every tube parameter affected by the cathode depends on proper heater voltage. Interrelationships such as these make electronics both fascinating and, at times, frustrating.

Many of the limiting factors that we have discussed are the same ones found in other electrical devices such as motors, stoves, toasters, and so on. Heating and overheating, insulation breakdown, and excessive voltage and current are all limitations that you have noted before.

The point is that you can and should apply just about everything you have learned about electricity to electron tubes. Little is new except the environment.

Q12. A large negative voltage is applied to the plate of a diode, and a large positive voltage is applied to the cathode. If the tube conducts, what tube parameter has been exceeded?

THE TRIODE

Diode electron tubes can be used as rectifiers, switches, and in many other useful applications. They are still used in Fleming's original application in some radio circuits. You will learn more of these

applications in other *NEETS* modules and later will see the diode in several pieces of electronic equipment.

As with all inventions, Fleming's diode was immediately the subject of much experimentation and many attempts at improvement. An American experimenter, Dr. Lee De Forest, added another active element to the diode in 1906. He was trying to improve the radio application of Fleming's diode. His new tube was eventually called a triode.

DeForest's triode was not very successful as a radio "detector." (Detectors will be studied in a later *NEETS* module.) However, in 1912, De Forest discovered that his original triode could **AMPLIFY** or magnify very weak electrical impulses. It is because of the triode's ability to amplify that De Forest is honored as one of the great radio pioneers.

The immediate application of the triode amplifier was in telephone and radio. Both fields were limited because electrical impulses (signals) became weaker and weaker as the distance from the signal source increased. The triode, along with other developments of the time, made long-distance communications possible. Looking back, we can now see that the amplifying tube was the real beginning of modern electronics and influenced everything that followed. Let's find out more about the idea of amplification and how it is done in the triode.

You are already familiar with a type of amplification. In a previous *NEETS* module, step-up transformers were discussed. You should remember that an input voltage applied to the primary of a step-up transformer is increased in amplitude at the secondary by a factor determined by the step-up turns ratio.

For example, if 5 volts were applied to the primary of a 1:3 step-up transformer, the secondary would produce 15 volts. In other words, the input voltage was amplified by a factor of 3. When applied to electronic circuits, these primary and secondary voltages are more often called signals, or input and output signal, respectively. In electronics, the amplitude of an input signal must sometimes be increased many times—often, hundreds or thousands of times!

Because of size and design limitations, transformers are usually not practical for use in electronics as amplifiers.

DeForest's first experiment with the diode was to place an additional metal plate between the cathode and plate. He then placed an ac signal on the metal plate. When the circuit was energized, De Forest found that the ammeter stayed on zero regardless of the polarity of the input signal.

What was happening was that the new element was blocking (or shadowing) the plate. Any electrons attempting to reach the plate from the cathode would hit the new element instead. As the circuit didn't work, it was back to the drawing board.

In his next attempt, De Forest decided to change the element between the cathode and the plate. Instead of a solid metal plate, he used a wire mesh. This would allow electrons to flow from the cathode, **THROUGH THE WIRE MESH**, to the plate. This tube circuit is shown in figure 1-15. In view (A) you see De Forest's circuit with 0 volts applied to the third element, (today called a control grid or occasionally just the grid). Under these conditions, assume that the ammeter reads 5 milliamperes. With no voltage applied to the grid, the grid has little effect on the electron stream. For all practical purposes, the control grid is not there. Most electrons flow through the open mesh. The tube functions as a diode.

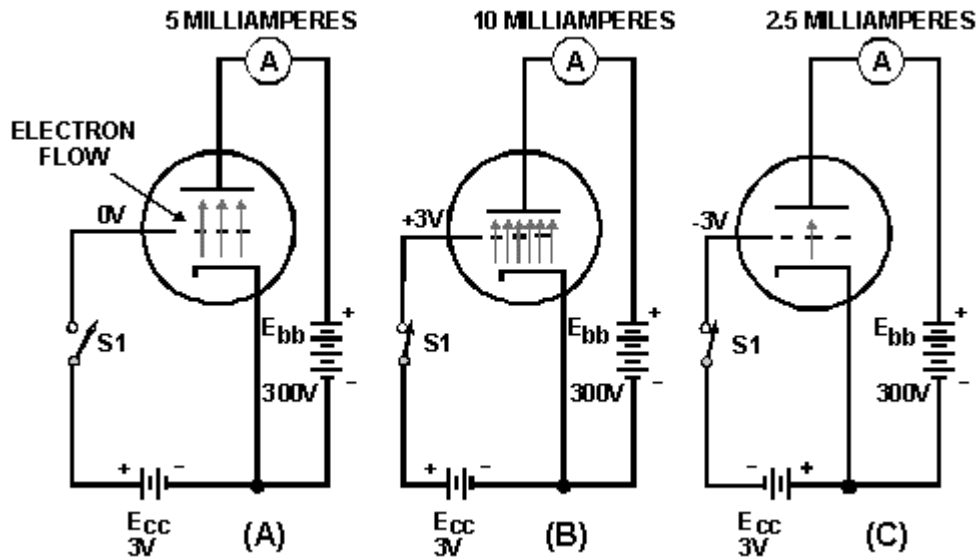

Figure 1-15.—DeForest's experiment.

In view (B), you see De Forest's tube with +3 volts applied to the control grid. When De Forest applied this voltage, he found that plate current, I_p , increased by a large amount. (We'll say it doubled to simplify the explanation.) You already know that the only way to double the plate current in a diode is to increase the plate voltage by a large amount. Yet, De Forest had doubled plate current by applying only 3 volts positive to the control grid!

The reason for this is fairly easy to understand. It's the old principle of "opposites attract." When the control grid was made positive, electrons surrounding the cathode (negative charges) were attracted to the grid. But remember, the grid is a metal mesh. Most of the electrons, instead of striking the grid wires, were propelled through the holes in the mesh. Once they had passed the grid, they were attracted to the positive charge in the plate.

You might wonder why the grid would make that much difference. After all, the plate has 300 volts on it, while the grid only has 3 volts on it. Surely the plate would have a greater effect on current flow than a grid with only one one-hundredth the attractive potential of the plate. But remember, in your study of capacitors you discovered that opposites attract because of electrostatic lines of force, and that the strength of electrostatic lines of force decreased with distance. In his tube, DeForest had placed the grid very close to the cathode. Therefore, it had a greater effect on current flow from the cathode than did the plate, which was placed at a much greater distance from the cathode. For this reason, De Forest was able to double the current flow through the tube with only +3 volts applied to the grid.

DeForest had certainly hit on something. Now the problem was to find out what would happen when a negative potential was applied to the grid. This is shown in view (C) of figure 1-15. When De Forest applied -3 volts to the grid, he found that plate current decreased to half of what it was when the grid had no voltage applied. The reason for this is found in the principle of "likes repel." The negatively charged grid simply repelled some of the electrons back toward the cathode. In this manner, the attractive effect of the plate was decreased, and less current flowed to the plate.

Now De Forest was getting somewhere. Using his new tube (which he called a triode because it had 3 elements in it), he was able to control relatively large changes of current with very small voltages. But! was it amplification? Remember, amplification is the process of taking a small signal and increasing its amplitude. In De Forest's circuit, the small input signal was 3 volts dc. What De Forest got for an output

was a variation in plate current of 7.5 milliamperes. Instead of amplification, De Forest had obtained "conversion," or in other words, converted a signal voltage to a current variation. This wasn't exactly what he had in mind. As it stood, the circuit wasn't very useful. Obviously, something was needed. After examining the circuit, De Forest discovered the answer—Ohm's law. Remember $E = I \times R$? De Forest wanted a voltage change, not a current change. The answer was simple:

$$\begin{array}{ccccccc} \text{If you want} & & \text{and you have} & & \text{simply add} & & \\ E & = & I & \times & R & & \end{array}$$

In other words, run the plate current variation (caused by the voltage on the grid) through a resistor, and cause a varying voltage drop across the resistor. This is shown in figure 1-16.

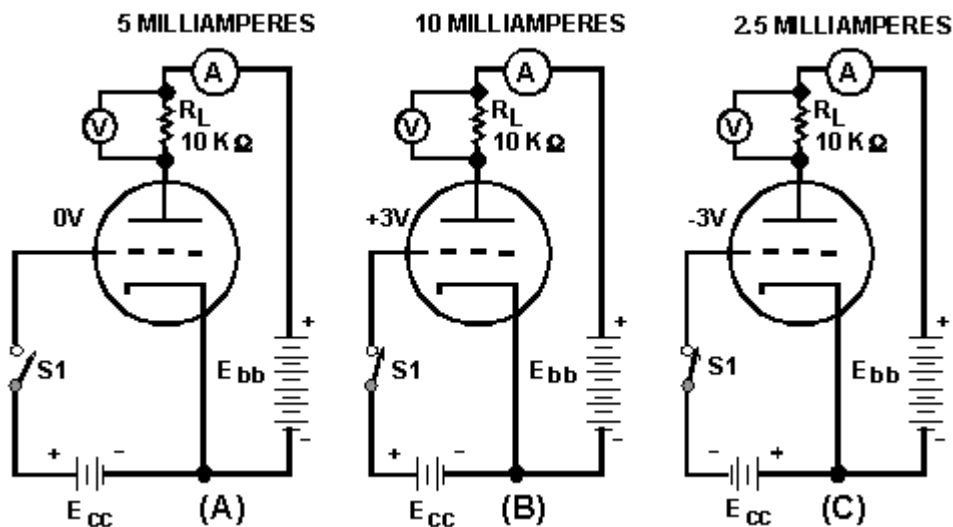

Figure 1-16.—Operation of the plate load resistor.

The circuit is identical to the one in figure 1-15 except that now a resistor (called a plate-load resistor, R_L) has been added to the plate circuit, and a voltmeter has been added to measure the voltage drop across R_L .

In view (A) of figure 1-16, the control grid is at 0 volts. Once again 5 milliamperes flow in the plate circuit. Now, the 5 milliamperes must flow through R_L . The voltage drop is equal to:

$$E = I \times R$$

$$E = (5 \times 10^{-3} \text{ amperes}) \times (10 \times 10^3 \text{ ohms})$$

$$E = (5 \times 10^{-3}) \times (10 \times 10^3)$$

$$E = 5 \times 10$$

$$E = 50 \text{ volts}$$

Thus the voltage drop across the plate-load resistor, R_L , is 50 volts when no voltage is applied to the grid. In view (B) of the figure, +3 volts is applied to the control grid. Once again plate current increases to 10 milliamperes. The voltage drop across R_L is

$$E = I \times R$$

$$E = (10 \times 10^{-3} \text{ amperes}) \times (10 \times 10^3 \text{ ohms})$$

$$E = (10 \times 10^{-3}) \times (10 \times 10^3)$$

$$E = 10 \times 10$$

$$E = 100 \text{ volts}$$

By applying +3 volts to the grid, the voltage drop across R_L was increased by 50 volts (from the original 50 volts to 100 volts). In view (C), -3 volts has once again been applied to the control grid. Once again plate current decreases to 2.5 milliamperes, and the voltage drop across R_L drops to 25 volts.

We have caused the voltage across R_L to vary by varying the grid voltage; but is it amplification? Well, let's take a look at it. The grid voltage, or input signal, varies from +3 to -3 volts, or 6 volts. The voltage drop across R_L varies from 25 volts to 100 volts, or 75 volts. In other words, the triode has caused a 6-volt input signal (varying) to be outputted as a signal that varies by 75 volts. That's amplification!

Q13. What is the primary difference between a diode and a triode?

Q14. Why does the grid have a greater effect than the plate on electron flow through a vacuum tube?

Q15. What component is used in a triode amplifier to convert variation in current flow to voltage variation?

Let's summarize what you have learned so far:

- A relatively small change in voltage on the grid causes a relatively large change in plate current.
- By adding a plate-load resistor in series with the plate circuit, the changing plate current causes a changing voltage drop in the plate circuit.
- Therefore, the small voltage change on the grid causes a large change of voltage in the plate circuit.
- By this process, the small input signal on the grid has been amplified to a large output signal voltage in the plate circuit.

We'll leave De Forest at this point. He showed that the control grid can, in fact, **CONTROL** plate current. He also showed that the changing plate current can create a changing plate voltage. To some degree, his changing voltages and currents also changed the world.

INTRODUCTION TO GRID BIAS

We purposely left out several features of practical triode circuits from the circuits we just discussed. We did so to present the idea of grid control more simply. One of these features is grid bias.

Let's take another look at the circuit in figure 1-15(B). We found that the positive charge on the grid caused more plate current to flow. However, when the grid becomes positive, it begins to act like a small plate. It draws a few electrons from the space charge. These electrons flow from the cathode across the gap to the positive grid, and back through the external grid circuit to the cathode. This flow is known as *grid current*. In some tube applications, grid current is desired. In others it is relatively harmless, while in some, grid current causes problems and must be eliminated.

Most amplifier circuits are designed to operate with the grid **NEGATIVE** relative to the cathode. The voltage that causes this is called a **BIAS VOLTAGE**. The symbol for the bias supply is E_{cc} . One effect of bias (there are several other very important ones) is to reduce or eliminate grid current. Let's see how it works.

GRID BIAS is a steady, direct voltage that is placed at some point in the external circuit between the grid and the cathode. It may be in the cathode leg or the grid leg as shown in figure 1-17. It is always in series with the input signal voltage. In each of the circuits in figure 1-17, E_{cc} makes the grid negative with respect to the cathode because of the negative terminal being connected toward the grid and the positive terminal being connected toward the cathode. With identical components, each circuit would provide the same bias.

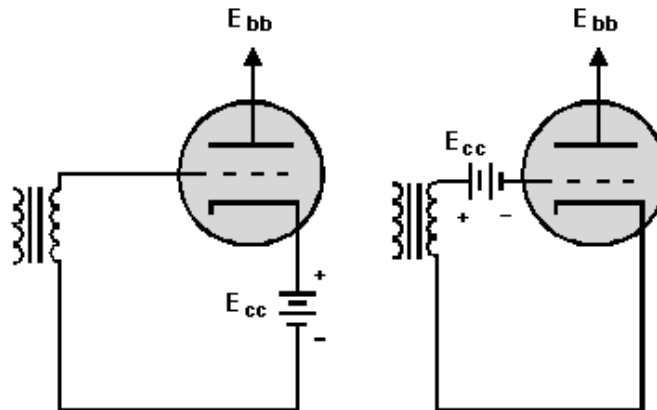
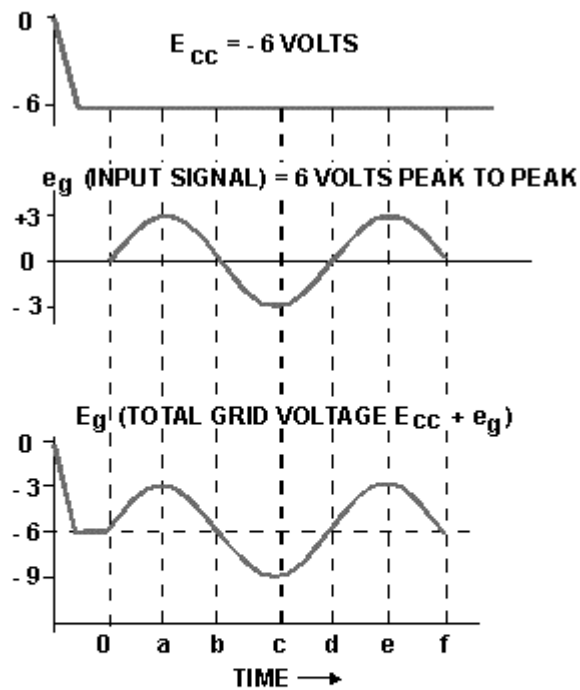

Figure 1-17.—Basic biasing of a triode.

Battery bias is practically never used in modern circuits. Because of its simplicity, however, we will use it in analyzing the effects of bias. We will present other, more practical methods later.

Let's assume that the bias voltage in figure 1-17 is -6 volts. Let's also assume that the peak-to-peak signal voltage from the transformer is 6 volts. Each of these voltage waveforms is shown in figure 1-18. From past experience you know that voltages in series **ADD**. Figure 1-18 has a table of the instantaneous values of the two voltages added together. The waveforms are drawn from these values.



TIME	0	a	b	c	d	e	f
BIAS (E_c)	-6	-6	-6	-6	-6	-6	-6
SIGNAL (e_g)	0	+3	0	-3	0	+3	0
TOTAL GRID VOLTS (E_g)	-6	-3	-6	-9	-6	-3	-6

Figure 1-18.—Typical grid waveforms.

Because the bias voltage is more negative than the signal voltage is positive, the resultant voltage (bias plus signal), E_g , is **ALWAYS** negative. The signal, in this case, makes the grid voltage go either **MORE** or **LESS NEGATIVE**, (-9 to -3) but cannot drive it positive.

Under these circumstances, the negative grid always repels electrons from the space charge. The grid cannot draw current. Any problems associated with grid current are eliminated, because grid current cannot flow to a negative grid.

You have probably already realized that the negative bias also reduces plate current flow. (Negative charge on grid-less plate current, right?) The trick here is for the circuit designer to choose a bias and an input signal that, when added together, do not allow the grid to become positive nor to become negative enough to stop plate current.

Tube biasing is very important. You will learn much more about it shortly. From this brief introduction, you should have learned that grid bias

- is a steady, direct voltage that in most cases makes the grid negative with respect to the cathode;
- is in series with the signal voltage between grid and cathode;

- acts to reduce or eliminate grid current;
- acts to reduce plate current from what it would be if no bias existed;
- is produced in other ways than just by a battery; and
- is important for reasons other than those just studied.

OPERATION OF THE TRIODE

The circuit in figure 1-19 brings together all of the essential components of a triode amplifier. Before analyzing the circuit, however, we need to define the term **QUIESCENT**.

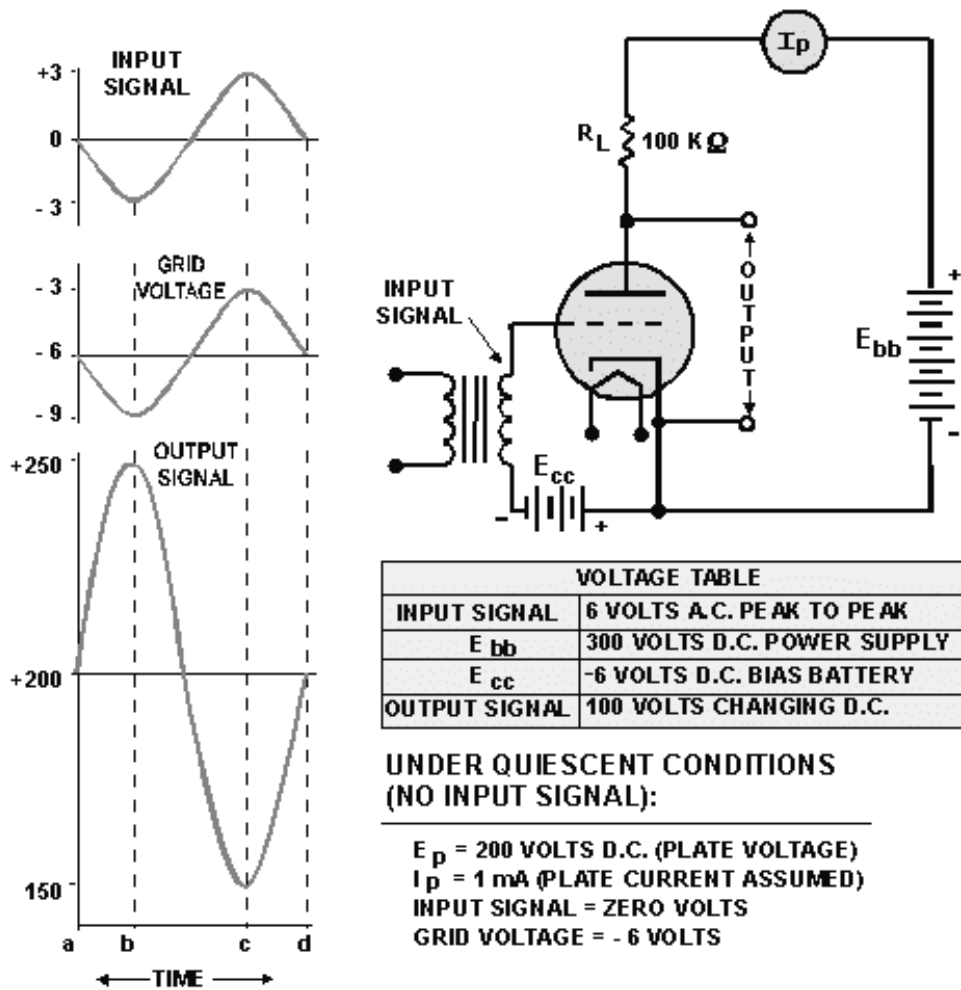

Figure 1-19.—Triode operation.

The term *quiescent* identifies the condition of a circuit with **NO INPUT SIGNAL** applied. With a given tube, bias supply, and plate supply, an exact amount of plate current will flow with no signal on the grid. This amount is known as the quiescent value of plate current. The quiescent value of plate voltage is the voltage between cathode and plate when quiescent current flows.

Simply, quiescent describes circuit conditions when the tube is not amplifying. The tube has no output signal and is in a kind of standby, waiting condition. Now let's go on to figure 1-19. With no input signal, under quiescent conditions, assume that 1 milliampere of current flows through the tube, cathode to plate. This current (I_p) will flow through R_L (load resistor) to the positive terminal of the battery. The current flowing through R_L causes a voltage drop (IR) across R_L equal to:

$$\begin{aligned} E &= I_p \times R_L \\ E &= 1 \times 10^3 \text{ amperes} \times 100 \times 10^3 \text{ ohms} \\ E &= 100 \text{ volts} \end{aligned}$$

Subtracting the voltage dropped across the plate-load resistor from the source voltage of 300 volts gives you 200 volts (300 volts - 100 volts). Thus, the plate voltage (E_p) is at 200 volts. The quiescent conditions for the circuit are:

$$\begin{aligned} \text{grid voltage} &= -6 \text{ volts} \\ \text{plate voltage } (E_p) &= +200 \text{ volts} \end{aligned}$$

These values are shown on the waveforms as time a in figure 1-19.

You should notice that even though the grid is more negative (-6 volts) than the cathode, the tube in the circuit is still conducting, but not as heavily as it would if the grid were at zero volts.

Now look at the input signal from the transformer secondary. For ease of explanation, we will consider only three points of the ac sine wave input: point b, the maximum negative excursion; point c, the maximum positive excursion; and point d, the zero reference or null point of the signal. At time b, the input signal at the grid will be at its most negative value (-3 volts). This will cause the grid to go to -9 volts (-6 volts + -3 volts). This is shown at time b on the grid voltage waveform. The increased negative voltage on the control grid will decrease the electrostatic attraction between the plate and the cathode. Conduction through the tube (I_p) will decrease. Assume that it drops to .5 milliamperes.

The decrease in plate current will cause the voltage drop across the plate-load resistor (R_L) to also decrease from 100 volts, as explained by Ohm's law:

$$\begin{aligned} E &= I_p \times R_L \\ E &= .0005 \text{ amperes} \times 100,000 \text{ ohms} \end{aligned}$$

or

$$\begin{aligned} E &= (.5 \times 10^{-3} \text{ amperes}) \times (100 \times 10^3 \text{ ohms}) \\ E &= 50 \text{ volts} \end{aligned}$$

Plate voltage will then rise +250 volts.

$$E_p = 300 \text{ volts} - 50 \text{ volts} = 250 \text{ volts}$$

This is shown on the output signal waveform at time b.

At time c, the input has reached its maximum positive value of +3 volts. This will decrease grid voltage to -3 volts (-6 volts + 3 volts). This is shown on the grid voltage waveform at time c. This in turn will increase the electrostatic force between the plate and cathode. More electrons will then flow from the

cathode, through the grid, to the plate. Assume that the plate current in this case will increase to 1.5 milliamperes. This will cause plate voltage (E_b) to decrease to 150 volts as shown below.

$$\begin{aligned}E &= I_P \times R_L \\E &= (1.5 \times 10^{-3} \text{ amperes}) \times (100 \times 10^3 \text{ ohms}) \\E &= 150 \text{ volts} \\E_P &= 300 \text{ volts} - 150 \text{ volts} \\E_P &= 150 \text{ volts}\end{aligned}$$

This is shown on the output waveform at time c.

At time d, the input signal voltage decreases back to zero volts. The grid will return to the quiescent state of -6 volts, and conduction through the tube will again be at 1 milliampere. The plate will return to its quiescent voltage of +200 volts (shown at time d on the output waveform).

As you can see, varying the grid by only 6 volts has caused the output of the triode to vary by 100 volts. The input signal voltage has been amplified (or increased) by a factor of 16.6. This factor is an expression of amplifier **VOLTAGE GAIN** and is calculated by dividing the output signal voltage by the input signal voltage.

Before going on to the next section, there is one more thing of which you should be aware. Look again at the waveforms of figure 1-19. Notice that the output voltage of the amplifier is 180° out of phase with the input voltage. You will find that this polarity inversion is a characteristic of any amplifier in which the output is taken between the cathode and the plate. This is normal and should not confuse you when you troubleshoot or work with this type of circuit.

- Q16. Why is the control grid of a triode amplifier negatively biased?*
- Q17. For a circuit to be considered to be in the quiescent condition, what normal operating voltage must be zero?*
- Q18. A triode amplifier similar to the one shown in figure 1-19 has an E_{bb} -350 volts dc. The plate-load resistor is 50 kΩ. Under quiescent conditions, 1.5 milliamperes of current conducts through the tube. What will be the plate voltage (E_p) under quiescent conditions?*
- Q19. A 2-volt, peak-to-peak, ac input signal is applied to the input of the circuit described in Q18. When the signal is at its maximum positive value, 2.5 milliamperes flows through the tube. When the input is at its maximum negative value, conduction through the tube decreases to .5 milliamperes.*
- What is the peak-to-peak voltage of the output signal?*
 - What is the phase relationship between the input and output signals?*

FACTORS AFFECTING TRIODE OPERATION

The triode circuit you have just studied is a fairly simple affair. In actual application, triode circuits are a bit more complex. There are two reasons for this. The first has to do with the triodes ability to amplify and perform other functions. Triodes come in many different types. Each of these types has different internal characteristics and different capabilities. Because of this, each triode circuit must be designed to accommodate the triodes special characteristics. The second reason for the increase in

complexity has to do with **DISTORTION**. Distortion occurs in a tube circuit any time the output waveform is not a faithful reproduction of the input waveform.

Polarity inversion and voltage gain of the output waveform are not included in this definition of distortion. Some circuits are designed to distort the output. The reason and methods for this deliberate distortion will be covered in a later *NEETS* module. For the most part, however, we desire that circuits eliminate or reduce distortion.

Because the grid is close to the cathode, small changes in grid voltage have large effects on the conduction of triodes. If a large enough input signal is placed on the grid, a triode may be driven into either plate-current cutoff or plate-current saturation. When this occurs, the tube is said to be **OVERDRIVEN**. Overdriving is considered to be a form of **DISTORTION**.

Look at time zero (0) in the waveforms of figure 1-20. The input signal (E_{in}) is at zero volts. Grid voltage equals the bias voltage (-6 volts), and one milliampere of current is flowing through the tube (quiescent state). Plate voltage (E_p) is 200 volts.

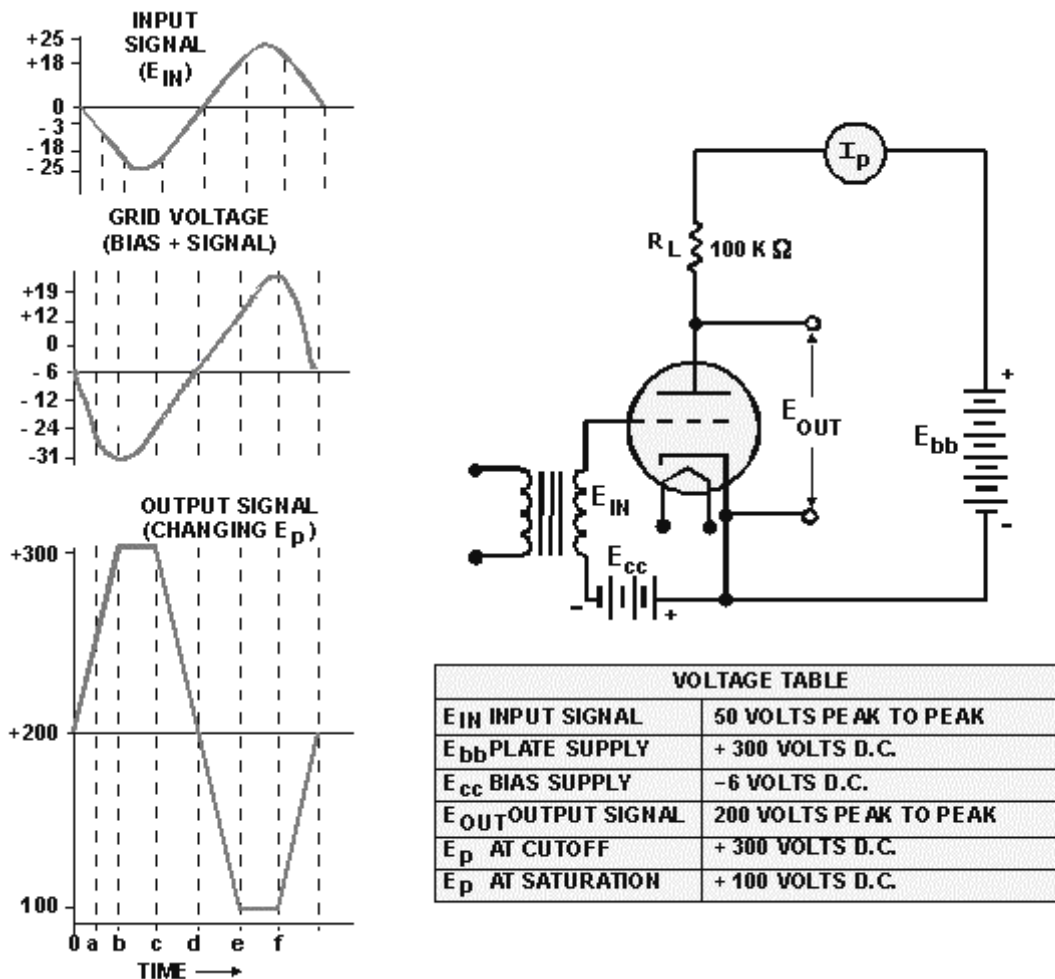

Figure 1-20.—Overdriven triode.

On the negative half of the input signal, the grid voltage is made more negative. This reduces plate current which, in turn, reduces the voltage drop across R_L . The voltage between cathode and the plate is thereby increased. You can see these relationships by following time "a" through the three waveforms.

Now, let's assume that this particular triode cuts plate current flow off when the grid reaches -24 volts. This point is reached at time b when E_{in} is -18 and the bias is -6 (-18 and -6 = -24). Plate current remains cut off for as long as the grid is at -24 volts or greater.

With zero current flowing in the plate circuit, there is no voltage drop across R_L . The entire plate-supply voltage, E_{bb} (300 volts), appears as plate voltage between the cathode and the plate. This is shown at time b in the output signal waveform. Between time b and time c, the grid voltage is greater than -24 volts. The plate current remains cutoff, and the plate voltage remains at +300. The output waveform between time b and time c cannot follow the input because the plate voltage cannot increase above +300 volts. The output waveform is "flattopped." This condition is known as **AMPLITUDE DISTORTION**.

When the grid voltage becomes less negative than -24 volts, after time c, the tube starts conducting, and the circuit again produces an output.

Between time c and time d, the circuit continues to operate without distortion. At time e, however, the output waveform is again distorted and remains distorted until time f. Let's see what happened.

Remember that every cathode is able to emit just so many electrons. When that maximum number is being emitted, the tube is said to be at **SATURATION** or **PLATE SATURATION**. Saturation is reached in a triode when the voltages on the grid and plate combine to draw all the electrons from the space charge.

Now, as our grid becomes less negative (between time c and time d), and actually becomes positive (between time d and time e), the plate current increases, the voltage across R_L increases, and the plate voltage decreases.

Apparently when the grid voltage reached +12 volts at time e, the plate current reached saturation. Maximum plate current (at saturation) results in maximum voltage across R_L and minimum plate voltage. Any grid voltage higher than +12 volts cannot cause further changes in the output. Therefore, between time e and time f, the plate voltage remains at +100 volts and the waveform is distorted. This is also **AMPLITUDE DISTORTION**.

This has been an explanation of one cycle of an input signal that overdrives the tube. You should notice that, using the same circuit, a 50-volt peak-to-peak input signal caused a vastly different output from that caused by the 6-volt peak-to-peak input signal. The 6-volt peak-to-peak signal did not overdrive the tube. When the input signal was increased to 50-volts peak-to-peak, the tube was forced into cutoff when the grid was driven to -24 volts, and into saturation when the grid was driven to +12 volts (the grid voltage plus the signal voltage.) During these periods, the tube could not respond to the input signal. In other words, the output was distorted. A method commonly used to partially overcome distortion is to vary the bias voltage on the grid. The point at which the tube goes into cutoff or saturation can then be controlled.

For this reason tube biasing is of great importance in most tube circuits.

Q20. The waveforms shown below are the input and output of an overdriven triode.

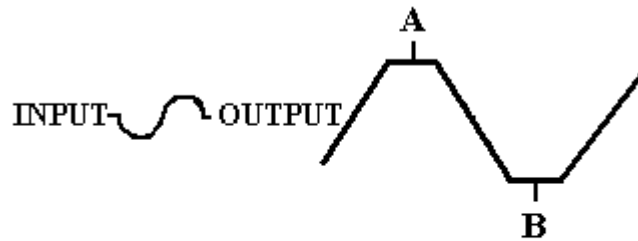

- a. Distortion A at the output is the result of what condition?
- b. Distortion B at the output is the result of what condition?

TYPES OF BIASING

There are two main classes of biasing—**FIXED** and **SELF**. In a tube circuit that uses fixed bias, the grid-bias voltage is supplied from a power source external to the circuit. You are already familiar with battery bias, which is one form of fixed bias. When fixed bias is used in a circuit, it can be represented as either a battery (fig. 1-21, view A), or as a conductor connected to $-E_{cc}$ (fig. 1-21, view B). Fixed bias is rarely used in electronics today. Therefore, we will not discuss it further.

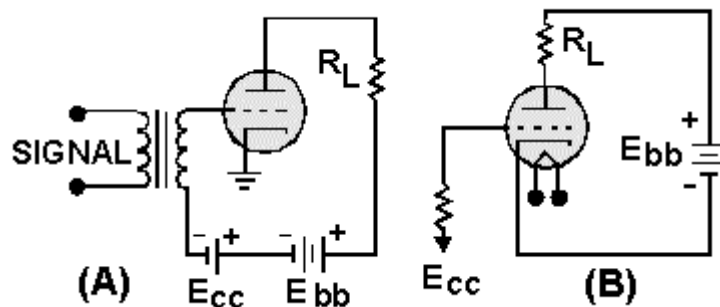

Figure 1-21.—Fixed bias: A. Battery B. Conductor

In circuits using self-bias, the bias voltage is developed across a resistor in the cathode or grid circuit by tube current. There are two main methods of self-bias: *cathode biasing* and *grid-leak biasing*.

Cathode Bias

In circuits using cathode bias, the cathode is made to go positive relative to the grid. The effect of this is the same as making the grid negative relative to the cathode. Because the biasing resistor is in the cathode leg of the circuit, the method is called **CATHODE BIASING** or **CATHODE BIAS**. A triode circuit using cathode bias is shown in figure 1-22.

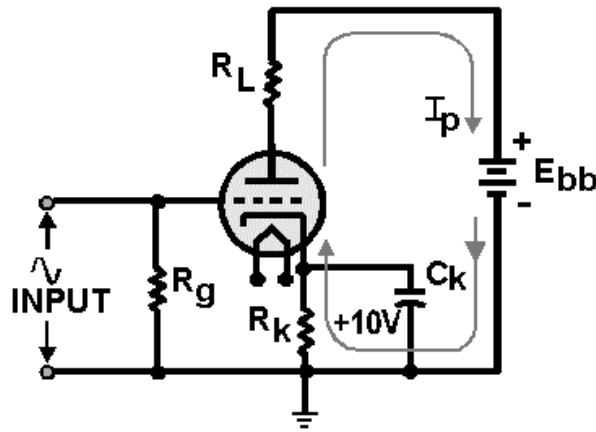

Figure 1-22.—Cathode bias.

The only difference between the illustrated circuit and the one used to demonstrate triode operation is the elimination of the battery, E_{cc} , and the addition of circuit components R_k , the cathode-biasing resistor; C_k , the cathode ac-bypass capacitor; and a grid resistor (whose purpose will be explained later).

When the tube conducts, current flows from the battery through R_k to the cathode, through the tube to the plate, and through R_L to the positive terminal of the battery. The current flowing through R_k will cause a voltage drop across R_k . The bottom of R_k goes negative while the top goes positive. This positive voltage at the top of R_k makes the cathode positive relative to the grid.

You may wonder what purpose C_k serves in this circuit. C_k serves as an **AC BYPASS**. Without C_k , the bias voltage will vary with ac input signals. This is particularly troublesome in the higher frequencies like those found in radio receivers. R_k , the cathode-biasing resistor, is used to develop the biasing voltage on the cathode.

The input signal will be developed across R_g . You will read more about the circuit component later in this chapter. Cathode-biasing voltage is developed in the following manner.

As we mentioned earlier, the bias voltage will vary with the input unless C_k , the cathode bypass capacitor, is used.

To understand how the bias voltage will vary with an ac input signal, disregard C_k for the moment and refer to figure 1-22 again.

Notice that under quiescent conditions, the voltage drop at the top of R_k is +10 volts. Now let's apply the positive-going signal illustrated to the left of the tube. When the positive signal is applied, conduction through the tube will increase. The only trouble is that current through R_k will also increase. This will increase the voltage drop across R_k , and the cathode voltage will now be greater than +10 volts. Remember, at this time the plate is going negative due to increased conduction through the tube. The combination of the negative-going plate and the positive-going cathode will decrease the electrostatic attraction across the tube and lower the conduction of the tube. This will reduce the gain of the tube.

When the negative-going signal is applied, conduction through the tube decreases. Current through R_k decreases and the voltage drop across R_k decreases. This causes the cathode to go more negative, which tends to increase conduction through the tube. A negative-going signal is amplified by decreasing plate current and allowing the plate to go positive (remember the 180° inversion.) Thus, increasing

conduction on the negative half-cycle decreases the gain of that half-cycle. The overall effect of allowing cathode biasing to follow the input signal is to decrease the gain of the circuit with ac inputs.

This problem can be overcome by installing C_k . The purpose of C_k is to maintain the cathode bias voltage at a constant level. In common usage, the action of C_k is referred to as "bypassing the ac signal to ground."

The action of C_k will be explained using figure 1-23. View A shows the circuit under quiescent conditions. With some conduction through the tube, the cathode and the tops of R_k and C_k are at +10 volts.

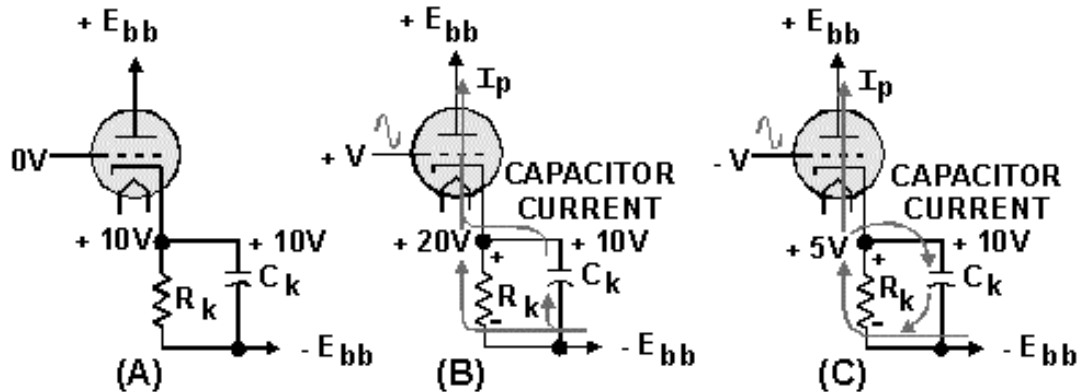

Figure 1-23.—Effect of the bypass capacitor.

In view B, the positive-going signal is applied to the grid. This causes increased conduction through the tube, which attempts to drive the cathode to +20 volts. But notice that the top of C_k is still at +10 volts (remember capacitors oppose a change in voltage). The top plate of C_k is, in effect, 10 volts negative in relation to the top of R_k . The only way that C_k can follow the signal on the top of R_k (+20 volts) is to charge through the tube back to the source, from the source to the lower plate of C_k . When C_k charges through the tube, it acts as the source of current for the cathode. This causes the cathode to remain at +10 volts while the capacitor is charging.

View C of the figure shows the same signal. Under these conditions, conduction through R_k will decrease. This will cause a decrease in current flow through R_k . Decreased current means decreased voltage drop. The top of R_k will try to go to +5 volts. C_k must now go more negative to follow the top of R_k . To do this, current must flow from C_k through R_k , to the top plate of C_k . This discharging of C_k will increase current flow through R_k and increase the voltage drop across R_k , forcing the top to go more positive. Remember, the voltage drop is due to current flow through the resistor. (The resistor could care less if the current is caused by conduction or capacitor action.) Thus, the cathode stays at +10 volts throughout the capacitor-charge cycle.

There is one point that we should make. C_k and R_k are in parallel. You learned from previous study that voltage in a parallel circuit is constant. Thus, it would seem impossible to have the top of R_k at one voltage while the top plate of C_k is at another. Remember, in electronics nothing happens instantaneously. There is always some time lag that may be measured in millionths or billionths of seconds. The action of C_k and R_k that was just described takes place within this time lag. To clarify the explanation, the voltages used at the components R_k and C_k were exaggerated. Long before a 10-volt differential could exist between the tops of R_k and C_k , C_k will act to eliminate this voltage differential.

The capacitor, then, can be said to regulate the current flow through the bias resistor. This action is considered as **BYPASSING** or eliminating the effect of the ac input signal in the cathode. For all practical purposes, you can assume that ac flows through the capacitor to ground. But, remember, ac only appears to flow across a capacitor. In reality the ac signal is shunted around the capacitor.

There are two disadvantages associated with cathode biasing. To maintain bias voltage continuously, current must flow through the tube, and plate voltage will never be able to reach the maximum value of the source voltage. This, in turn, limits the maximum positive output for a negative input signal (remember the 180° inversion). In addition, maximum plate voltage is decreased by the amount of cathode-biasing voltage. What this means is that you can't get something for nothing. If the cathode is biased at +20 volts, this voltage must be subtracted from the plate voltage. As an example, consider a triode with a 10,000 ohm plate resistor and a +300 volts dc source voltage. If a current of 2 milliamperes flows through the tube under quiescent conditions, 20 volts are dropped across the plate-load resistor. The maximum plate voltage is then 300 volts - 20 volts = 280 volts dc. Now, consider the 20-volt dropped across the cathode resistor. Plate voltage becomes 280 volts - 20 volts = 260 volts. To understand this a little more thoroughly, look at figure 1-24. In view A, the source voltage is 300 volts dc. There are two ways that this voltage can be looked at; either the plate is at +300 volts and the cathode is at 0 volts (ground), or the plate is at +150 volts and the cathode is at -150 volts. In electronics, it is common practice to assume that the plate is at +300 volts while the cathode is at 0 volts. To simplify this discussion, we will assume that the plate is at +150 volts, and the cathode is at -150 volts. The potential difference between the plate and the cathode is 300 volts. If a plate-load resistor is installed, as shown in view B, 20 volts are dropped by R_L . The potential difference between the plate and the cathode is now 280 volts. In view C, R_k has now been placed in the same circuit. R_k drops 20 volts. Therefore, the effect of cathode biasing is to reduce the maximum positive signal that the circuit can produce. In this case, the maximum positive signal has been reduced by 20 volts. Despite these disadvantages, cathode biasing has two main advantages. It is simple and economical.

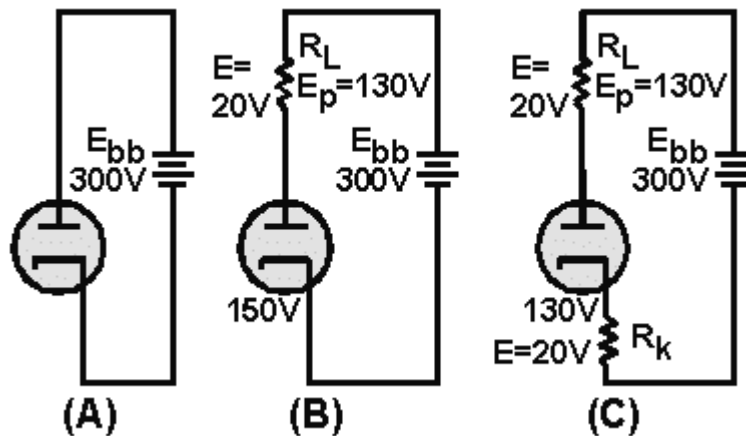

Figure 1-24.—Loss due to cathode biasing.

Grid-Leak Biasing

The second type of self-biasing to be discussed is **GRID-LEAK BIAS**. As the name implies, bias voltage is developed in the grid leg portion of the circuit. Bias voltage in this type of biasing is derived by allowing the positive input signal to draw grid current through a circuit made up of a resistor and a capacitor. There are two types of grid-leak bias commonly in use: **SHUNT TYPE** and **SERIES TYPE**. Because shunt type grid-leak biasing is the simplest, we will discuss it first. Figure 1-25 depicts a simplified triode circuit using the shunt-type grid-leak biasing. Before we begin the explanation of shunt

grid-leak biasing, there is one thing you should bear in mind. Because the bias is derived from the positive input signal through capacitive action, the input signal must go through several positive alternations before the final operating bias voltage is achieved. We will explain why this is so in the following discussion.

View A of figure 1-25 shows the circuit under quiescent conditions. You will notice that the circuit is similar to the one we used to explain the action of a triode. The only additions are the grid resistor, R_g , coupling capacitor, C_c , and resistance rgk . Resistance rgk doesn't exist as a physical component, but it is used to represent the internal tube resistance between the triode's cathode and grid. Electrically, rgk is quite small, about 500 ohms. Under quiescent conditions, some conduction occurs through the tube. Some electrons will strike the wires of the grid, and a small amount of **GRID CURRENT** will flow through R_g to ground. This will cause the right-hand plate of C_c to go slightly negative. This slight negative charge will, in turn, keep the grid of the tube slightly negative. This limits the number of electrons that strike the grid wires.

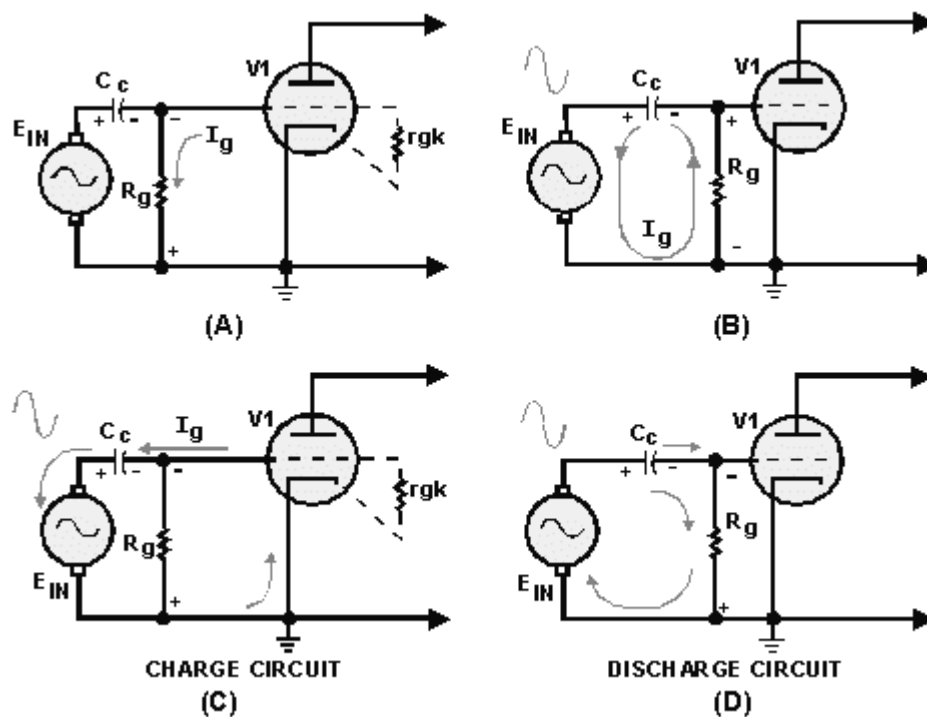

Figure 1-25.—Shunt grid-leak biasing.

In view B of the figure, the first positive alternation of a series of ac alternations, E_{in} is applied to the circuit. The positive-going voltage causes the left-hand plate of C_c to go positive. The left-hand plate must lose electrons to go positive. These electrons leave the left-hand plate of C_c and travel to the input source where they will be coupled to ground. From ground, current flows through R_g causing a negative (bottom) to positive (top) voltage drop across R_g . In effect, the ac signal has been coupled across the capacitor. Because of this, capacitors are said to pass the ac signal while blocking dc. (In reality, the ac signal is coupled around the capacitor.) In view C of the figure, the positive-going voltage at the top of R_g will be coupled to the grid causing the grid to go positive. The positively charged grid will attract electrons from the electron stream in the tube. Grid current will flow from the grid to the right-hand plate of C_c . This will cause the right-hand plate to go negative. (Electrostatic repulsion from the right-hand plate of C_c will force electrons from the left-hand plate of C_c , causing it to go positive.) The electrons will flow through the signal source, to ground, from ground to the cathode, from the cathode to the grid, and finally to the

right-hand plate of C_c . This is the biasing charge cycle. You may wonder why the charge current went through the tube rather than through R_g . When the grid goes positive in response to the positive-going input signal, electrostatic attraction between the grid and cathode increases. This, in turn, reduces the resistance (rgk) between the grid and cathode. Current always follows the path of least resistance. Thus, the capacitor charge path is through the tube and not through R_g .

When the first negative alternation is applied to the circuit (view D), the left-hand plate of C_c must go negative. To do this, electrons are drawn from the right-hand plate. The electrons travel from the right-hand plate of C_c , through R_g causing a voltage drop negative (top) to positive (bottom), from the bottom of R_g , through the source, to the left-hand plate of C_c . C_c will discharge for the duration of the negative alternation. **BUT C_c can only discharge through R_g , which is a high-resistance path, compared to the charge path.** Remember from your study of capacitors that **RC** time constants and the rate of discharge increase with the size of **R**. C_c can therefore charge through the low resistance of rgk to its maximum negative value during the positive half-cycle. Because C_c discharges through R_g (the high resistance path), it cannot completely discharge during the duration of the negative half-cycle. As a result, at the completion of the negative alternation, C_c still retains part of the negative charge it gained during the positive alternation. When the next positive alternation starts, the right-hand plate of C_c will be more negative than when the first positive alternation started.

During the next cycle, the same process will be repeated, with C_c charging on the positive alternation and discharging a lesser amount during the negative alternation. Therefore, at the end of the second cycle, C_c will have an even larger negative charge than it did after the first cycle. You might think that the charge on C_c will continue to increase until the tube is forced into cutoff. This is not the case. As the negative charge on the right-hand plate of C_c forces the grid more negative, electrostatic attraction between the grid and cathode decreases. This, in effect, increases the resistance (rgk) between the cathode and the grid, until rgk becomes, in effect, the same size as R_g . At this point, charge and discharge of C_c will equal one another and the grid will remain at some negative, steady voltage. What has happened in this circuit is that C_c and R_g , through the use of unequal charge and discharge paths, have acted to change the ac input to a negative dc voltage. The extent of the bias on the grid will depend on three things: the amplitude of the input, the frequency of the input, and the size of R_g and C_c . This type of biasing has the advantage of being directly related to the amplitude of the input signal. If the amplitude increases, biasing increases in step with it. The main limiting factor is the amount of distortion that you may be willing to tolerate. Distortion occurs during the positive alternation when the grid draws current. Current drawn from the electron stream by the grid never reaches the plate; therefore the negative-going output is *not* a faithful reproduction of the input, while the positive-going output (during the negative input cycle) *will be* a faithful reproduction of the input. This is similar to the situation shown in the flattened portion of the output signal in figure 1-20.

The **SERIES GRID-LEAK BIAS** circuit shown in figure 1-26 operates similarly to the shunt grid-leak circuit. When the first positive alternation is applied to the left-hand plate of the grid capacitor, C_g , the left-hand plate must lose electrons to go positive with the input. Electrons will leave the left-hand plate and flow through R_g , causing a negative (left-hand side) to positive (right-hand side) voltage drop. From the right-hand side of R_g , the electrons will flow to the right-hand plate of C_g . The positive voltage developed at the right-hand side of R_g will be coupled to the grid. As the grid goes positive, it will draw current, causing C_g to start to charge through the low resistance path of the tube. During the negative alternation of the input, C_g will discharge through the high resistance path of R_g . Once again it will not be completely discharged at the end of the negative alternation, and the capacitor will continue on its way toward charge equilibrium.

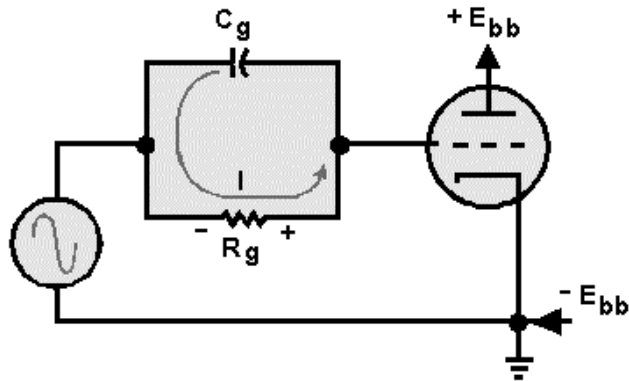

Figure 1-26.—Series grid-leak biasing.

In summary, grid-leak bias causes the grid to draw current when the input signal goes positive. This grid current (which is a negative charge) is stored by the coupling capacitor (C_c) which will keep the grid at some negative potential. It is this potential that biases the tube.

- Q21. What type of bias requires constant current flow through the cathode circuit of a triode?
- Q22. When a circuit uses cathode biasing, the input signal can cause variations in the biasing level. How is this problem eliminated?
- Q23. In a circuit using grid-leak biasing, the coupling capacitor (C_c) charges through a low resistance path. What resistance is used in this charge path?
- Q24. Grid-leak biasing in effect rectifies the input ac signal. What feature of the circuit is used to accomplish this rectification?

OPERATING CLASSIFICATIONS OF TUBE AMPLIFIERS

While the discussion of amplifiers will be covered in detail in later *NEETS* modules, some discussion of the classes of operation of an amplifier is needed at this point. This is because their operation class is directly determined by the bias voltage of the tube.

The classification of amplifiers by operation is based on the percentage of the time that the tube conducts when an input signal is applied. Under this system amplifiers may be divided into four main classes: A, AB, B, and C.

CLASS A OPERATION

An amplifier biased into Class A operation, is one in which conduction through the tube occurs throughout the duration of the input signal. Such an amplifier is shown in figure 1-27, view A. This is the same type of circuit with which you are already familiar. Notice when you compare the input to the output that the tube is always conducting, and that the entire input signal is reproduced at the output.

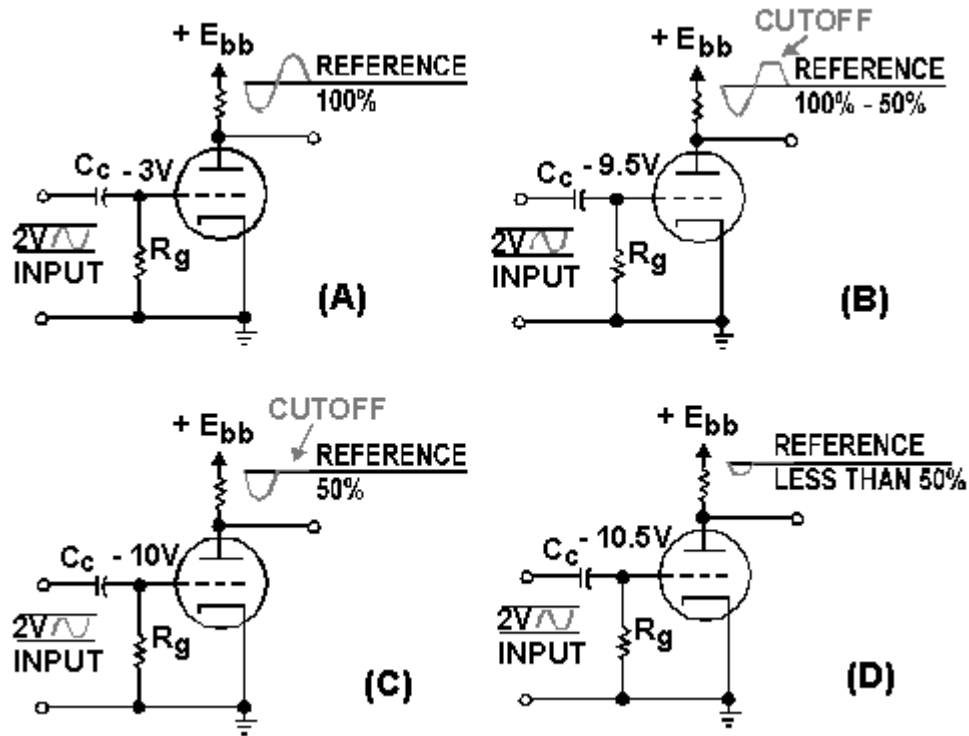

Figure 1-27.—Classes of amplifier operation.

CLASS AB OPERATION

The Class AB amplifier is one in which the tube conducts for more than half, but less than the entire input cycle.

View B of figure 1-27 depicts an amplifier biased into **CLASS AB** operation. Notice that in this application, grid bias has been increased to -9 volts. We will assume that the tube reaches cutoff when the voltage on the grid is -10 volts. Under these conditions, when the input reaches -10 volts, the tube will cut off and stay cut off until the input goes above -10 volts. The tube conducts during the entire duration of the positive alternation and part of the negative alternation. If you remember back in the discussion of distortion, we pointed out that this represents distortion. In some amplifiers, faithful reproduction of the input is not an important requirement. Class AB amplifiers are used only where this distortion can be tolerated.

CLASS B OPERATION

A **CLASS B** biased amplifier is one in which the tube will conduct for only half of the input signal duration. This is done by simply biasing the amplifier at cutoff. View C of figure 1-27 depicts a class B biased amplifier.

As you can see, the tube conducts on the positive alternations. As soon as the input signal voltage reaches 0 volts, the tube cuts off. The tube will remain cut off until the input signal voltage climbs above zero volts on the next positive alternation. Because the tube conducts during the entire positive alternation, but not on the negative alternation, the tube conducts for only half the input cycle duration.

CLASS C

CLASS C amplifiers are biased below cutoff, so that the tube will conduct for less than half of the input signal cycle duration. View D of figure 1-27 depicts a Class C amplifier. Notice that the tube is biased one-half volt below cutoff. The tube will only conduct on that part of the positive alternation that is above +.5 volts. Therefore, the tube conducts for less than one-half cycle of the input. Again, this class can be applied only where severe distortion can be tolerated.

TUBE CONSTANTS

In the discussion of triodes, we only considered the effects of the external circuit on the passage of current through the tube. The behavior of the electron stream in a conducting tube is also influenced by the physical structure of the tube. The effects that the physical structure of a tube has on the tube's operation are collectively called **TUBE CONSTANTS**. Four of the most important of these tube constants are: **TRANSIENT TIME**, **INTERELECTRODE CAPACITANCE**, **TRANSCONDUCTANCE**, and **AMPLIFICATION FACTOR**.

TRANSIT TIME

Unlike electron flow in a conductor, electrons in a vacuum tube do not move at the speed of light. Their velocity is determined by the potential difference between the plate and the cathode. The amount of time the electrons take to travel from the cathode to the plate is called **TRANSIT TIME**. As a result of this time difference, the appearance of a signal at the end of a tube is not followed instantaneously by a change in current flow in the tube. Under normal conditions, the effect of this small time lag between the input signal and a change in tube current is unnoticed. However, at frequencies such as those used in radar equipment, this is not the case. Transit time at these frequencies has a very marked effect on tube operation. It is a major factor that limits the use of a given tube at higher frequencies.

Q25. Match each amplifier characteristic listed below with its class of amplification.

- a. Current flows through the tube for one-half cycle.*
- b. Current flows through the tube for less than one-half cycle.*
- c. Current flows through the tube for the entire cycle.*

MU AND TRANSCONDUCTANCE

In your study of triodes so far, you have seen that the output of a triode circuit is developed across the tube. The output is caused by the voltage dropped across R_L due to current flow from tube conduction. In all the demonstrations of gain, we assumed that R_L was held constant and current through the tube was varied. In this manner we achieved a voltage gain. If the resistance of R_L is changed by the designer, the gain of a triode circuit can be either increased or decreased. This is fairly easy to understand. Assume that a circuit is composed of a triode with a plate-load resistor of 100 kohms. If a +2 volt signal causes 2 additional milliamperes to conduct through the tube, the voltage drop across R_L (the output) will be:

$$\begin{aligned}
E &= I \times R \\
E &= I_p \times R_L \\
E &= (2 \times 10^{-3} \text{ amperes}) \times (100 \times 10^3 \text{ ohms}) \\
E &= 2 \times 100 \text{ volts} \\
E &= 200 \text{ volts}
\end{aligned}$$

$$\begin{aligned}
\text{Gain} &= \frac{\text{output}}{\text{input}} \\
\text{Gain} &= \frac{200 \text{ volts}}{2 \text{ volts}} \\
\text{Gain} &= 100
\end{aligned}$$

Thus, the gain of the circuit is 100. If the plate-load resistor is reduced to 50 kohms and the input is kept at +2 volts, the gain will be reduced to:

$$\begin{aligned}
E &= (2 \times 10^{-3} \text{ amperes}) \times (50 \times 10^3 \text{ ohms}) \\
E &= 2 \times 50 \text{ volts} \\
E &= 100 \text{ volts}
\end{aligned}$$

$$\begin{aligned}
\text{Gain} &= \frac{100 \text{ volts}}{2 \text{ volts}} \\
\text{Gain} &= 50
\end{aligned}$$

As you can see, voltage gain depends on both the tube characteristics and the external circuit design.

The voltage gain is a measure of circuit efficiency, not tube efficiency.

The actual characteristics of a tube are measured by two factors: μ (μ) or **AMPLIFICATION FACTOR**; and **TRANSCONDUCTANCE** or g_m . The amplification factor (represented as μ) of a tube is equal to the ratio of a change in plate voltage to the change in grid voltage required to cause the same change in plate current. This is expressed mathematically as

$$\mu = \frac{\Delta E_p}{\Delta E_g}$$

While this may sound complicated, it really isn't. Look at figure 1-28. Here you see in view A a triode with a +1 volt input signal. At this grid voltage, current through the tube is at 1 milliamperes. If the input voltage is raised to +3 volts, current through the tube increases to 2 milliamperes. The change in E_g (ΔE_g) is then 2 volts. This is shown in view B. Suppose that the grid voltage is returned to +1 volt, and the plate voltage is increased until the ammeter in view C reads 2 milliamperes of plate current. At this point plate voltage is measured. Plate voltage had to be increased by 100 volts (350-250) to get the same change in plate current (1 mA). The change in plate voltages (ΔE_p) is then 100 volts. The amplification factor (μ) of just the tube is then equal to

$$\mu = \frac{\Delta E_p}{\Delta E_g}$$

$$\mu = \frac{100 \text{ volts}}{2 \text{ volts}}$$

$$\mu = 50$$

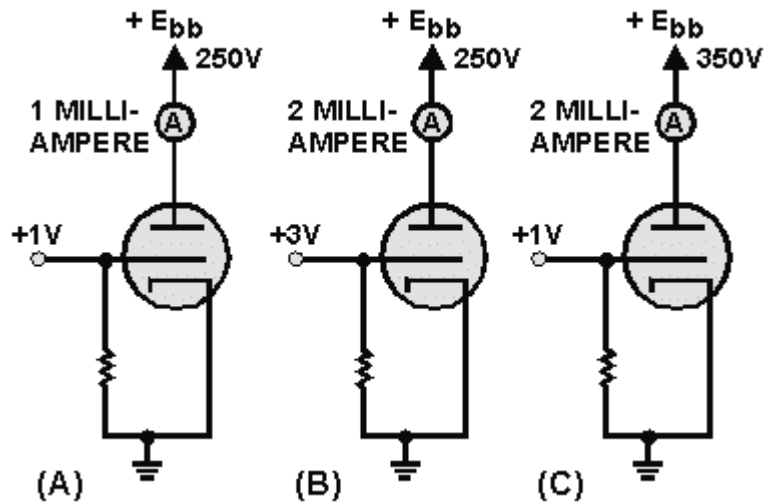

Figure 1-28.—Obtaining gain and transconductance.

As you can see, mu is a measure of the ability of a tube to amplify. By comparing the mu of two different types of tubes, you can get an idea of their efficiency. For example, assume you have two different tubes, one with a mu of 50, and the other with a mu of 100. If you place each tube in a circuit whose input varies by 2 volts, you can expect the following changes in plate voltage.

Tube 1:

$$\mu = \frac{\Delta E_p}{\Delta E_g}$$

$$\Delta E_p = \mu \times \Delta E_g$$

$$\Delta E_p = 50 \times 2 \text{ volts}$$

$$\Delta E_p = 100 \text{ volts}$$

Tube 2:

$$\mu = \mu \times \frac{\Delta E_p}{\Delta E_g}$$

$$\Delta E_p = \mu \times \Delta E_g$$

$$\Delta E_p = 100 \times 2 \text{ volts}$$

$$\Delta E_p = 200 \text{ volts}$$

Thus, you can expect twice the change in plate voltage from tube 2 as from tube 1 for the same input voltage. Therefore, tube 2 will have twice the gain of tube 1.

Transconductance

Transconductance is a measure of the change in plate current to a change in grid voltage, with plate voltage held constant. The unit for conductance is the mho (siemens), pronounced "moe."

Transconductance is normally expressed in either micromhos or millimhos. Mathematically, transconductance is expressed by the formula:

$$gm = \frac{\Delta I_p}{\Delta E_g}$$

Examine figure 1-28, views A and B, again. In view A, the input voltage is +1 volt. At +1 volt E_g , the plate current is equal to 1 milliamperes, with a plate voltage of 250 volts. In view B, the input voltage (E_g) is raised to +3 volts. ΔE_g , as before, is equal to 2 volts. This increase in grid voltage causes plate current to increase to 2 milliamperes. The change in plate current (ΔI_p) is then equal to 1 milliamperes. Thus, transconductance (g_m) is equal to:

$$gm = \frac{\Delta I_p}{\Delta E_g}$$

$$gm = \frac{1 \text{ milliamperes}}{2 \text{ volts}}$$

$$gm = .5 \text{ millimho} \\ \text{or } 500 \mu\text{mhos}$$

Remember that the voltage gain of a circuit is measured by the ratio of the change in plate voltage to the change in grid voltage. Because plate voltage is developed across a resistor, the more current varies with a given input signal, the greater will be the output ($E = I \times R$). If you have two tubes, one with a gm of 500 mmhos & the other with a gm of 500 μ mhos, you can estimate the relative gain of these two tubes. Assume that the circuit in which you wish to use one of these tubes has a load resistor of 100 kohms and that ΔE_g will be 2 volts. The voltage gain of these two circuits will be:

Tube 1:

$$gm = \frac{\Delta I_p}{\Delta E_g}$$

$$\Delta I_p = \Delta E_g \times gm$$

$$\Delta I_p = 2 \times 5 \text{ millmho}$$

$$\Delta I_p = 1 \text{ milliampere}$$

$$\Delta E_p = \Delta I_p \times R_L$$

$$\Delta E_p = (1 \times 10^{-3} \text{ ampere}) \times (100 \times 10^3 \text{ ohms})$$

$$\Delta E_p = 100 \text{ volts}$$

$$\text{Gain} = \frac{\text{output}}{\text{input}}$$

$$\text{Gain} = \frac{100 \text{ volts}}{2 \text{ volts}} = 50$$

Tube 2:

$$gm = \frac{\Delta I_p}{\Delta E_g}$$

$$\Delta I_p = \Delta E_g \times gm$$

$$\Delta I_p = 2 \text{ volts} \times 5 \text{ millmho}$$

$$\Delta I_p = 10 \text{ milliampere}$$

$$\Delta E_p = \Delta I_p \times R_L$$

$$\Delta E_p = (10 \times 10^{-3} \text{ ampere}) \times (100 \times 10^3 \text{ ohms})$$

$$\Delta E_p = 1000 \text{ volts}$$

$$\text{Gain} = \frac{\text{output}}{\text{input}}$$

$$\text{Gain} = \frac{1000 \text{ volts}}{2 \text{ volts}} = 500$$

As you can see, tube 2 is 10 times the amplifier that tube 1 is.

- Q26. The plate voltage of a tube will vary 126 volts when a 3-volt ac signal is applied to the control grid. What is the gain of this tube?
- Q27. If the μ of a tube is 85 and the signal at the control grid is 4 volts ac, the plate voltage will vary by what amount?
- Q28. Transconductance is a measure of the relationship between what two factors?
- Q29. A tube has a transconductance of 800 mmhos & a load resistor of 50 kohms. When control grid voltage varies by 6 volts, the plate voltage will vary by what amount?

INTERELECTRODE CAPACITANCE

As you know, capacitance exists when two pieces of metal are separated by a dielectric.

You should also remember from your studies that a vacuum has a dielectric constant of 1. As the elements of the triode are made of metal and are separated by a dielectric, capacitance exists between them. This capacitance is called *interelectrode capacitance*, and is schematically represented in figure 1-29.

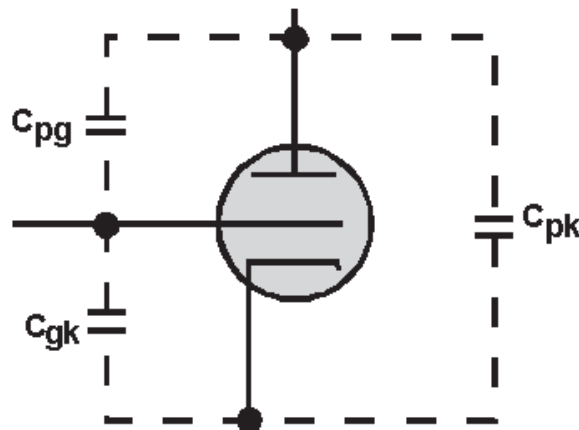

Figure 1-29.—Schematic representation of interelectrode capacitance.

Notice that there are three interelectrode capacitances involved in a triode. The capacitance between the plate and grid, designated C_{pg} , is the largest, because of the relatively large area of the plate, and therefore has the greatest effect on triode operation. The grid-to-cathode capacitance is designated C_{kg} .

The total capacitance across the tube is designated C_{pk} .

As we said earlier, C_{pg} has the greatest effect on the tube operation. This is because this capacitance will couple part of the ac signal from the plate back to the grid of the tube. The process of coupling the output of a circuit back to the input is called **FEEDBACK**. This feedback affects the gain of the stage. It may be desirable in some applications. In others, the effects must be neutralized. The effects of C_{pk} are greater at higher frequencies where X_c is lower.

DEVELOPMENT OF THE TETRODE

Interelectrode capacitance cannot be eliminated from vacuum tubes, but it can be reduced. The easiest method found to reduce interelectrode capacitance is to split the capacitance between the grid and plate (C_{pg}) into two capacitors connected in series. This is done by placing an extra grid, called the **SCREEN GRID**, between the control grid and the plate. This is shown in figure 1-30.

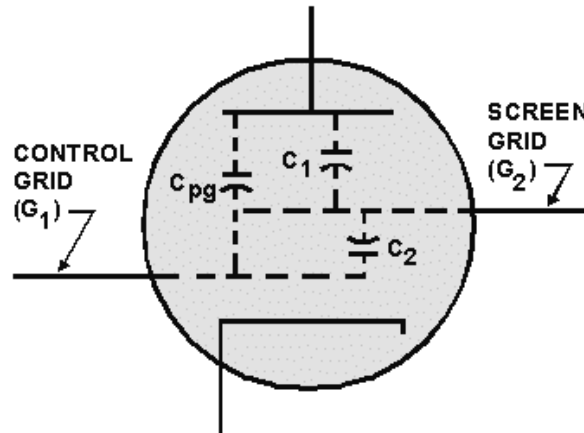

Figure 1-30.—Effect of the screen-grid on Interelectrode capacitance.

Remember from your study of capacitance that connecting capacitors in series reduces the total capacitance to a value smaller than either of the capacitors. This is mathematically summed up as follows:

$$C_T = \frac{C_1 \times C_2}{C_1 + C_2}$$

The addition of the screen grid has the effect of splitting C_{pg} into two capacitances (C_1 and C_2) connected in series. Therefore, the total interelectrode capacitance between the control grid and the plate is greatly reduced.

OPERATION OF THE BASIC TETRODE CIRCUIT

Figure 1-31 depicts a basic tetrode circuit. While the circuit may look complicated, it isn't. You are already familiar with most of the circuit. Only three components have been added: the screen grid, the screen grid dropping resistor, and the screen grid bypass capacitor (C_{sg}).

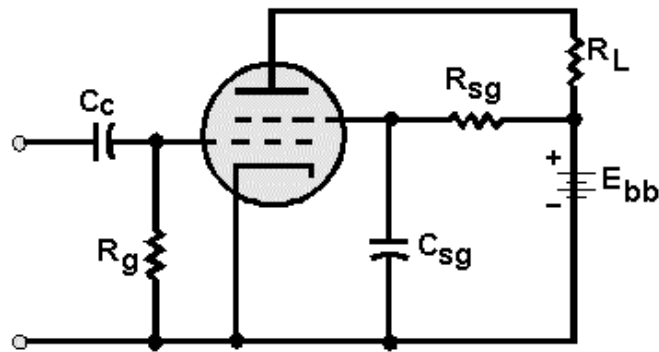

Figure 1-31.—Basic tetrode circuit.

The problem now is: at what voltage and polarity should the screen grid be operated? If the screen grid were operated at a potential that would make it negative in relation to the control grid, it would act as a negative screen between the plate and control grid. As a result, gain would be reduced. If the screen grid were operated at plate potential, it would draw current from the electron stream when the tube conducts. Because of this, the value of R_{sg} is normally selected to cause the screen grid to be positive in relation to the control grid, but not as positive as the plate.

Despite this precaution, the screen grid still draws some current from the electron stream. Any signal applied to the control grid will appear at the screen grid inverted by 180° from the input signal. This is undesirable, as it reduces the gain of the tube. Consider the effect if the control grid goes positive. Conduction through the tube increases, and since the screen grid is in the electron stream, it will draw some current. This causes the screen grid to go toward negative potential (less positive). The effect then, is to place a negative-going electrode between the plate and positive-going control grid. The plate becomes partially screened by the negative-going screen grid, and again, gain will decrease. Because the signal at the screen grid is always 180° out of phase with the control grid, its effect will always be to oppose the effect of the control grid.

To overcome this, a bypass capacitor (C_{sg}) is connected between the screen grid and ground. The addition of this capacitor will shunt, or pass, the ac variations on the screen grid to ground while maintaining a steady dc potential on the screen grid. In other words, C_{sg} moves all of the undesired effects mentioned in the previous paragraph.

One very useful characteristic of the tetrode tube is the relationship between the plate and screen grid. The screen grid will lessen the effect that a decreasing plate potential (negative-going signal) has on conduction through the tube. In a triode, when the grid goes positive, the plate goes negative. This decreases electrostatic attraction across the tube and tends to decrease the gain somewhat.

In a tetrode, the screen grid has the ability to isolate the effect that ac variations on the plate have on the electron stream.

The positively charged screen grid will accelerate electrons across the tube even though the plate is negative going. As long as the plate remains positive in relation to the cathode, it will draw off these accelerated electrons. As a result, conduction through the tube when the plate is going negative will not be decreased. This is another big advantage of screen-grid tubes.

TETRODE CHARACTERISTICS

Because the screen grid is in the electron stream, it will always draw some current. The current drawn by the screen grid will be lost to the plate. This means that the transconductance of a tetrode, which is based on the amount of plate current versus control-grid voltage, will be lower in tetrodes than in triodes. The formula for transconductance of a triode,

$$g_m = \frac{\Delta I_p}{\Delta E_g}$$

must be adjusted for screen-grid current, and becomes

$$g_m = \frac{\Delta I_p - \Delta I_{sg}}{\Delta E_g}$$

As you can see, the transconductance for a tetrode can never be as high as that of a triode of similar construction.

While lowered transconductance in a tetrode is an undesirable characteristic, it is not the reason that tetrodes have found little acceptance in electronics. The factor that severely limits the operation of tetrodes is **SECONDARY EMISSION**.

Because the screen grid is positively charged, electrons traveling from the cathode to the plate are accelerated. Electrons are accelerated to such an extent that they dislodge electrons from the plate when they strike it. This is similar to the manner in which a high-velocity rifle bullet fired into a pile of sawdust throws sawdust about. Some of these electrons are fired back into the tube, where they tend to accumulate between the screen grid and the plate. This effect is most pronounced when the signal at the control grid is going positive and conduction through the tube is increasing. The plate in this situation is going negative in answer to the control-grid signal. This causes the electrons accumulating between the plate and screen grid to be attracted to the screen grid. The current that is drawn by the screen grid is lost to the plate and gain is decreased. Gain is also decreased in another way. The negative charge accumulated by secondary emission causes some of the electrons (from the cathode) to be repelled from the plate, which further reduces gain.

Another undesirable characteristic of tetrodes associated with secondary emission is that the outputs are **NOISY**. What this means is that small sporadic signals appear on the main output signal, as shown in figure 1-32. When electrons are knocked from the plate, they represent losses of plate current and corresponding positive pulses on the output. Electrons falling back to the plate represent increases in plate current and cause negative-going pulses to appear in the output.

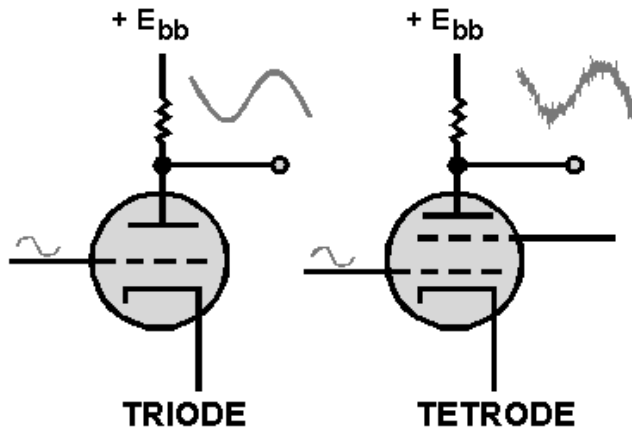

Figure 1-32.—Noise in a tetrode circuit.

For these reasons tetrodes are only used in very specialized applications of electronics.

Q30. How does the addition of a screen grid in a tetrode reduce interelectrode capacitance?

Q31. What undesirable effect does the screen grid in a tetrode create?

THE PENTODE

The problem of secondary emission associated with the screen grid of a tetrode has been reduced by—you guessed it, the addition of another grid.

This third grid, called a **SUPPRESSOR GRID**, is placed between the screen grid and the plate. The suppressor grid is normally connected either internally or externally to the cathode and bears the same charge as the cathode. This is shown in figure 1-33. Because of its negative potential (relative to individual electrons), any electrons that are emitted by the plate, through secondary emission, are repelled back toward the plate.

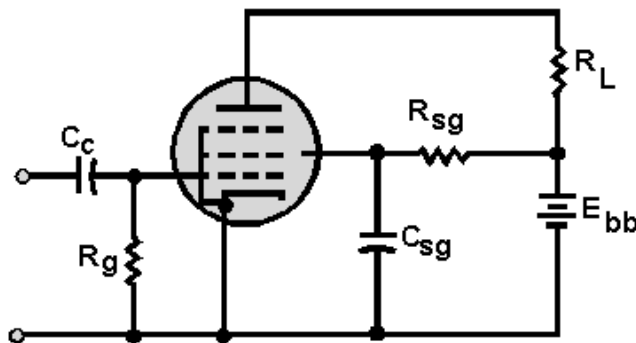
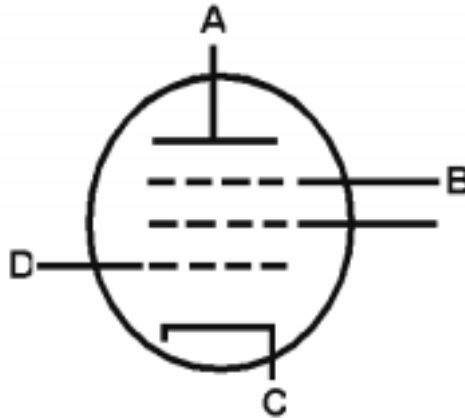

Figure 1-33.—Basic pentode circuit.

You might think that a grid with a negative potential placed close to the plate would interfere with the electron stream. However, this is not the case. Because the suppressor grid is negatively charged, it will not draw grid current. Additionally, the wide spacing within the mesh of the suppressor and its location between two positive elements of the tube ensures that the suppressor grid's effect on the electron stream will be minimum. Only the electrons emitted by secondary emission from the plate are affected by the suppressor grid.

Because pentodes do not suffer from secondary emission, they have replaced the tetrode in most applications.

- Q32. *The suppressor grid is added to a tetrode to reduce what undesirable characteristic of tetrode operation?*
- Q33. *On the diagram below, name the elements of the vacuum tube and their potentials relative to dc ground.*



SUMMARY

This chapter has introduced you to the four basic types of vacuum tubes. The following is a summary of the main points of the chapter.

THERMIONIC EMISSION is caused when metallic substances are heated to high temperatures. Electrons liberated by thermionic emission provide the conduction currents of vacuum tubes.

A **DIODE VACUUM TUBE** is composed of two elements: the cathode and the plate.

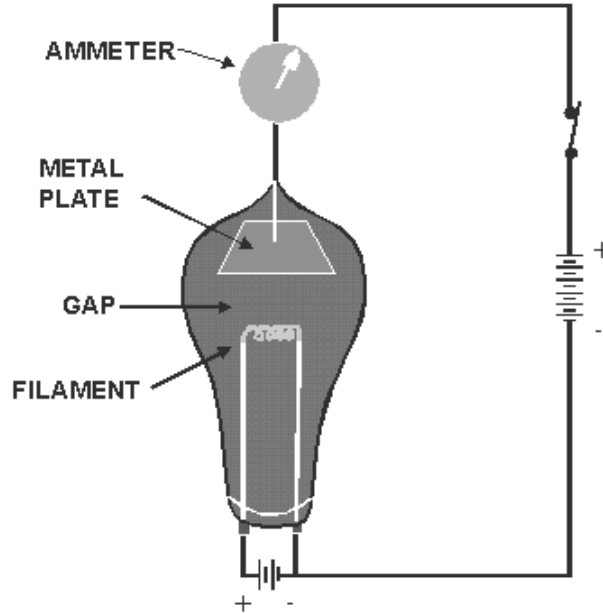

The **CATHODE** is the electron-emitting element of a tube. Cathodes are usually composed of special materials that are heated either directly or indirectly.

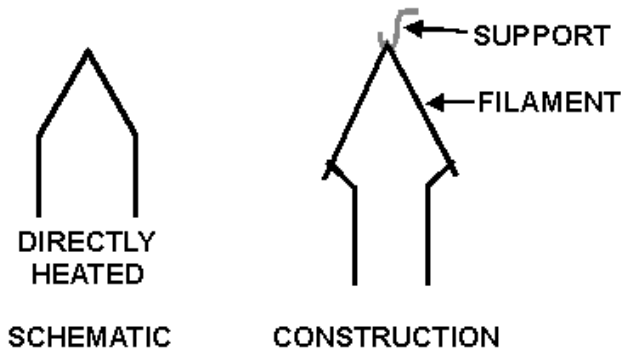

DIODE OPERATION depends upon current flow through the tube. Because the cathode is the only electron-emitting element in the tube, current can only flow in one direction, from the cathode to the plate. For current to flow, the plate must be positive relative to the cathode. When the plate is negative relative to the cathode, current cannot flow within the tube.

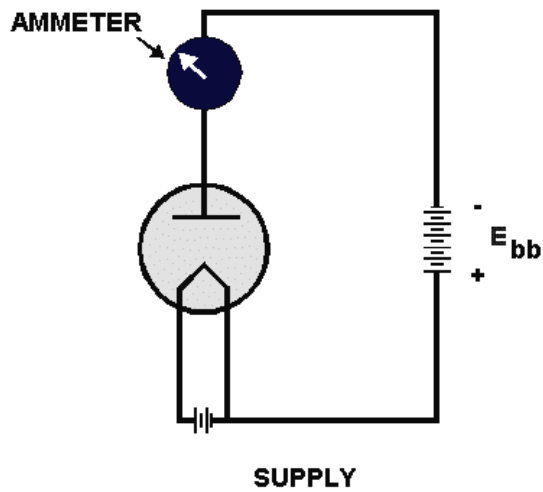

The **CHARACTERISTIC CURVE** for an electron tube is a graphic plot of plate current (I_p) versus plate voltage (E_p). From this, dc plate resistance can be computed by the formula:

$$R_p = \frac{E_p}{I_p}$$

FACTORS THAT LIMIT VACUUM TUBE OPERATION are plate dissipation, maximum average current, maximum peak-plate current, and peak-inverse voltage.

DIODE RECTIFIERS take advantage of the fact that diodes will conduct in only one direction. When ac voltages are applied to diodes, conduction occurs only on the alternation that makes the plate positive relative to the cathode. Because of this, the output current consists of one polarity. Because it flows in pulses rather than continuously, it is called pulsating dc.

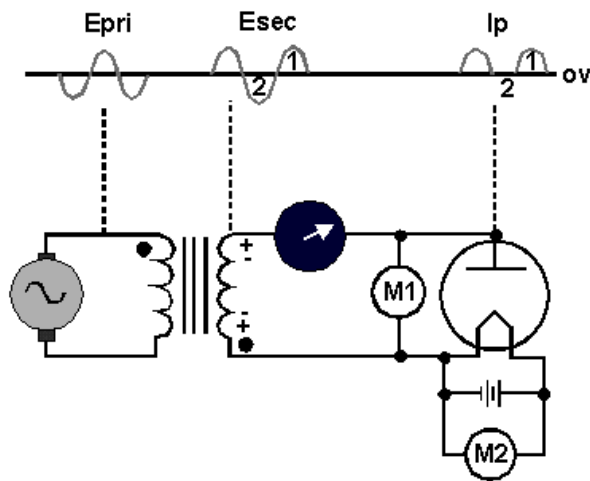

DIODE CONSTRUCTION is the basic construction plan of most vacuum tubes. The tube is constructed of the following parts: filament and/or cathodes, plates, envelope, and base.

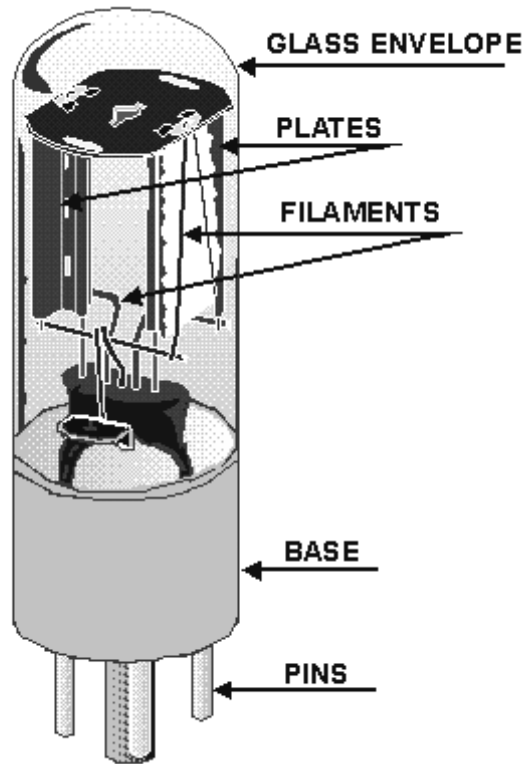

A **TRIODE** is basically a diode with a control grid mounted between the plate and the cathode. The control grid gives the triode the ability to amplify signals.

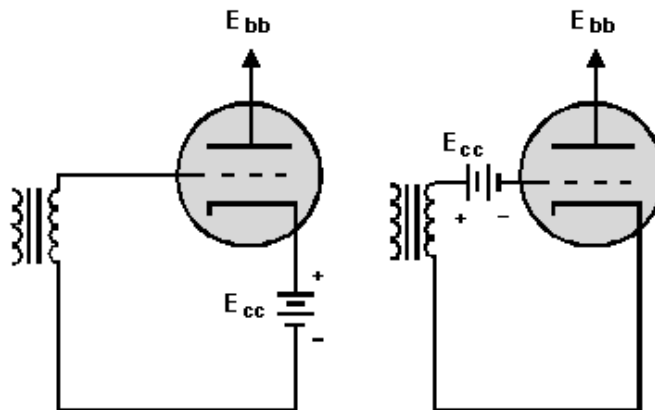

The **OPERATION OF A TRIODE** depends on the ability of the control grid to either increase or decrease conduction through the tube in response to an ac input signal. The output voltage is developed across the tube between the cathode and plate because of the voltage drop across the plate-load resistor changing as the plate current responds to the input signal.

TUBE BIASING is the process of placing a dc voltage, usually negative, on the grid. Bias has several functions in circuit design. Biasing may be divided into two types: fixed and self. Tubes using fixed bias have a dc voltage applied to their control grids from an external source such as a battery. Self-

biasing voltages, on the other hand, are derived from current conducting through the tube. The most common types of self-biasing are cathode biasing and grid-leak biasing.

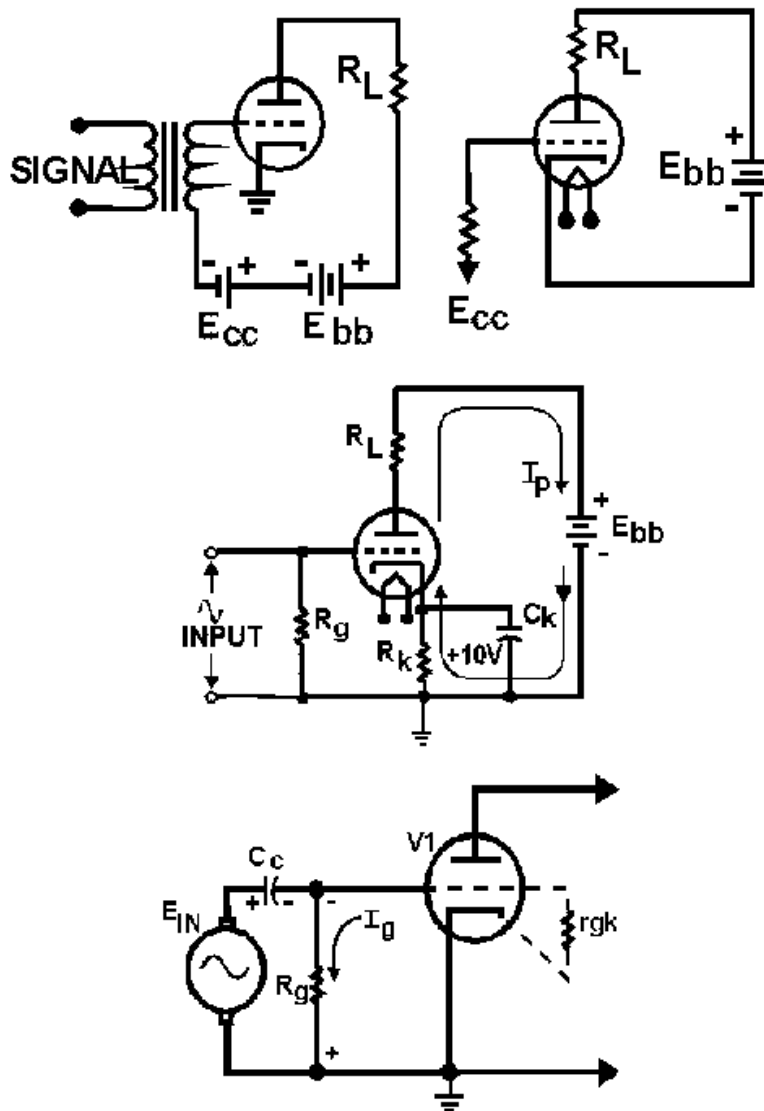

The **CLASS OF OPERATION OF AN AMPLIFIER** is determined by the bias applied to a triode. An amplifier operating as class A conducts continually through the duration of the input cycle. Class AB operation occurs when the amplifier conducts for more than half but less than the entire duration of the input cycle. A class B amplifier conducts for only 50% of the input cycle. The class C amplifier conducts for less than half of the input cycle.

TRANSIT TIME is the time required for electrons emitted by the cathode to reach the plate. Because transit time in a vacuum tube is considerably less than the speed of light, vacuum tube operation is affected at high frequencies.

INTERELECTRODE CAPACITANCE is created by the naturally occurring capacitance between elements in a vacuum tube. One effect of interelectrode capacitance is to feed back a portion of the output

of a triode to the input. This effect is a prime-limiting factor in applying triodes. It is a major reason why triodes are seldom used—especially at the higher frequencies.

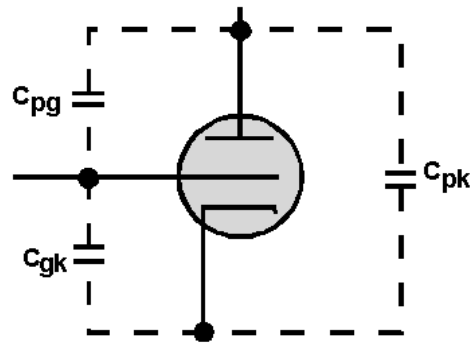

MU AND TRANSCONDUCTANCE are measures of tube efficiency. Mu (μ), or amplification factor, is a measure of the amount that plate voltage varies in relation to variation of the input voltage. Mathematically, mu (μ) is expressed as

$$\mu = \frac{\Delta E_p}{\Delta E_g}$$

TRANSCONDUCTANCE, on the other hand, is a measure of the amount of variation of plate current caused by a variation of the input signal. Mathematically, it is expressed as:

$$gm = \frac{\Delta I_p}{E_g}$$

TETRODES were developed to compensate for the effects of interelectrode capacitance. Placing a positively charged screen grid between the control grid and plate has the effect of adding a capacitor in series with the capacitance that exists between the control grid and plate. This reduces total capacitance below the value of either capacitor as shown by applying the formula:

$$C_T = \frac{C_1 \times C_2}{C_1 + C_2}$$

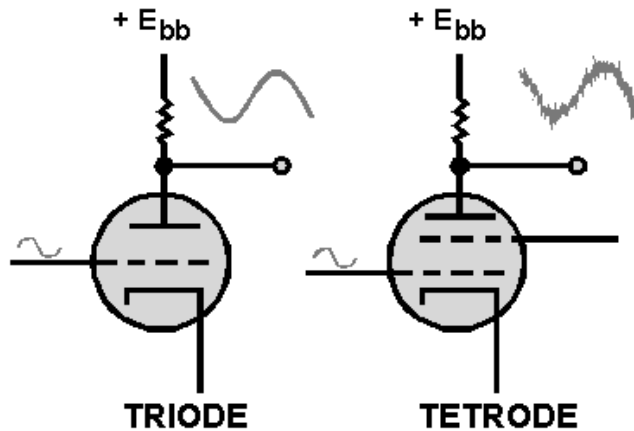

SECONDARY EMISSION of electrons from the plate is caused by the acceleration of electrons by the screen grid. This causes the performance of a tetrode to be degraded. In addition to reduced amplitude, the output signals become noisy.

PENTODES do not suffer from the effects of secondary emission. This is because a negatively charged suppression grid placed between the screen grid and plate forces any electrons emitted back to the plate.

ANSWERS TO QUESTIONS Q1. THROUGH Q33.

- A1. *By heating it.*
- A2. *Because the negatively charged electrons are attracted to the positively charged plate.*
- A3. *Filament and plate.*
- A4. *Negative.*
- A5. *Positive.*
- A6. *Pulsating dc.*
- A7. *Thoriated-tungsten and oxide-coated metals.*
- A8. *They reach operating temperatures quickly.*
- A9. *It serves as a mounting for the tube elements and as the terminal connection to the circuit.*
- A10. *The linear portion.*
- A11. *Plate resistant R_p .*
- A12. *Peak Inverse Voltage (PIV).*
- A13. *The triode contains a third element called the control grid.*
- A14. *Because it is closer to the cathode.*

- A15. *A plate load resistor R_L*
- A16. *To prevent them from drawing grid current.*
- A17. *The input signal*
- A18. *+275 volts.*
- A19.
- a. *100 volts.*
 - b. *180° out of phase.*
- A20.
- a. *Cutoff.*
 - b. *Saturation.*
- A21. *Cathode biasing.*
- A22. *Through the use of a bypass capacitor*
- A23. *r_{kg} , the cathode to grid resistance.*
- A24. *Unequal charge and discharge paths of the coupling capacitor C_c .*
- A25.
- a. *Class B.*
 - b. *Class C*
 - c. *Class A.*
- A26. *42.*
- A27. *340 volts.*
- A28. *The changes in plate current and grid voltage.*
- A29. *240 volts.*
- A30. *The interelectrode capacitance (c_{pg}) is divided between two series capacitances; thus, c_{pg} is greatly reduced.*
- A31. *Secondary emission, and noise.*
- A32. *Secondary emission.*

A33.

- a. *Plate, positive.*
- b. *Suppressor grid, negative.*
- c. *Cathode, can be negative, positive, or at dc ground potential, depending on biasing type.*
- d. *Control grid, negative.*